



**LIDO 14
CLASS
ASSOCIATION**



**HANDBOOK AND CLASS ROSTER
2002-2003**

Brief History of the Lido 14

The history of the Lido 14 begins with Barney Lehman, of Newport Beach, California. Barney's business, Plastaglass Co, designed and manufactured sailboats - most notably the Lehman 10 and the Lehman 12 cat rigged dinghys.

Barney introduced the Lehman 14 - Essentially a larger Lehman 12. In 1955 W.D. Schock Co. purchased Plastaglass and its designs.

W.D. Schock Co. had made its name building quality wood one-design dinghys such as the International 14, Snipe, Finn, and Thistle. Though W.D. Schock Co. built and sold a few Lehman 14s using the Plastaglas design, it was clear that the boat would not be successful as designed.

Responding to demands for a more stable and family friendly boat, Bill started with the Lehman 14 molds, modified their shape, added sloop rigging, positive buoyancy, a deck, storage space, better foils, a rotating centerboard, and a variety of other improvements. The result was far more stable and comfortable and was an immediate success. It was called the Lido 14. The year was 1958.

The Lido 14 design was quite revolutionary for it's time. It was elegant, stable, easy to use, affordable, and manufactured with modern methods. The response was tremendous. Lido 14 #1 completed in early February of 1958 and taken delivery by Les Littlejohn of Lido Island (Newport Beach, CA). By early March of 1959, #200 was being built. In the subsequent year, almost 400 were built. Production continued at a phenomenal rate for quite a few years.

By the late 1980's, as was the case in much of the industry, production had reduced to a trickle. With the remodeled Lido 14 making its introduction in the fall of 1995, interest picked back up. By late 2001, over 200 "6000" Series Lido 14s had been built.

LEHMAN DINGHY FLEET
FIBER GLASS BOATS

8-ft. Lehman Lehman '10' Lehman 12-ft. 14-ft. Lehman

DEALERS:
Fresno
Clawson Boat Works
Blackstone Ave.

Newport
Robert Vaughan & Co.
1600 W. Coast Hwy.
Phone: Liberty 87805

PLASTAGLAS CO.
504 29th St. Phone: Harbor 1578
Newport Beach, Calif.
DIVISION OF SCHOCK BROTHERS
Builders of Int. 14, Thistle and Highlander

September 1955 Advertisement in Sea Magazine for Plastaglas sailboats

Lido 14 Class Association
P.O. Box 1252
Newport Beach, CA 92663

www.lido14.org

Table of Contents

Brief History of the Lido 14	C2
Roster	
2002-2003 Governing Board	2
Previous Class Presidents	3
District Map	3
Regions & Districts	4
Fleets	5
Member Roster - Alphabetical	6-7
Member Roster - By Fleet	8-22
Member Roster - By Boat Number	68, C3
Class Championships	
Class Championship Regatta	23-31
Western Regional Championship Regatta	39
Junior Class Championship Regatta	41-44
Advertisements	32-33 & 36-37
Measurement Drawing	34-35
By-Laws	45-62
Measurement Rulings	
Approved Changes	62-66
Disallowed Changes	67

2002-2003 Governing Board & Administrators

President	David Carroll (Fleet 7) 2753 West Avenue N8 Palmdale, CA 93551	661/266-0368 davecarroll@antelecom.net
Vice President	Tom Jenkins (Fleet 59) P.O. Box 1326 Arroyo Grande, CA 93421	805/489-1832 th11688@aol.com
Secretary	Fred Stevens (Fleet 6) 105 Prospect Long Beach, CA 90803	562/438-8354 FS3CPA@aol.com
Treasurer	Jeanne Smith (Fleet 6) 12 Sirius Irvine, CA 92612	949/725-9780 dandjsmith@earthlink.net
Chief Measurer	Eric Kownacki (Fleet 7) 18674 Locksley Street San Diego, CA 92128	858/487-3782 eric@polarispool.com
Director	Derek Paulin (Fleet 6) 3030 Arrowhead Drive Los Angeles, CA 90068	323/464-9313 dpaulin@earthlink.net
Director	John Gresham (Fleet 6) 5846 Pavo Street Long Beach, CA 90808	562/425-1986 john@gresham.com
Director	Chris Collins 23930 Via Onda Valencia, CA 91355	818/842-3667 ccollsail@aol.com
Hon. Director	Tom Schock W.D. Schock Corp. 23125 Temescal Canyon Road Corona, CA 91719	909/277-3777 schock@wdschock.com www.wdschock.com
Past President	John Papadopoulos (Fleet 1) 20242 Spruce Avenue Newport Beach, CA 92660	949/863-1458 jakp@mindpsring.com
Exec. Secretary	Sharon Young P.O. Box 4056 Costa Mesa, CA 92628-4056	714/437-1370 714/437-1374 FAX steno2@email.msn.com

Previous Class Presidents

John Papadopoulos	2002	Pete Jefferson	1977
John Papadopoulos	2001	Don Bradbury	1976
Jim Jackman	2000	Chuck Cover	1975
Roger Tilton	1999	Chuck Babcock	1974
Roger Tilton	1998	Gared N. Smith	1973
Dave Smith	1997	Jim Tyler	1972
Dave Smith	1996	Paul Hubay	1971
Don Brown	1995	Dick Van Duzer III	1970
Greg Cotton	1994	Ed Rodriguez	1969
Greg Cotton	1993	Bill McCord	1968
Bob Yates	1992	Roy Woolsey	1967
Kent Foster	1991	A.V. "Bud" Jones	1966
Kent Foster	1990	Dario Sanchez	1965
Chris Erickson	1989	Gib Marshall	1964
Chris Erickson	1988	M.A. Anderson	1963
Roger Patterson	1987	Marty Lockney	1962
Dave Larson	1986	Mac Horn	1961
Don Barrus	1985	Art Reaume	1960
Gary Thorne	1984	C.L. Smith	1959
Dave Carroll	1983	Dick Wilson	1958
Charlie Cummings	1982	Les Littlejohn	
John McDonald	1981		
Jerry Tankersley	1980		
Ted Hinshaw	1979		
Kelly Snow	1978		

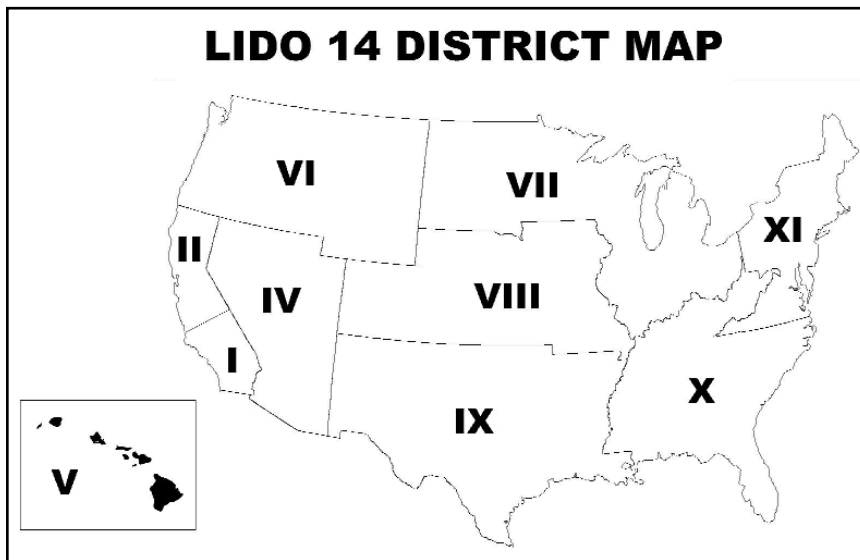

Regions & Districts

Regions

Western Districts I, II, IV, V, VI
Central Districts VII, VIII, IX
Eastern Districts X, XI

Districts

- I Southern California
 - Fleet 1 Newport Harbor, California
 - Fleet 6 Alamitos Bay, California
 - Fleet 7 Mission Bay, California
 - Fleet 9 King Harbor, California

- II Northern California
 - Fleet 59 Morro Bay, California
 - Fleet 62 Fremont, California

- IV Southwest
 - Fleet 79 Utah

- V Hawaii **Inactive**

- VI Northwest
 - Fleet 25 Portland, Oregon
 - Fleet 36 Rogue Valley, Oregon
 - Fleet 77 North Olympic, Washington
 - Fleet 78 Anacortes, Washington
 - Fleet 80 Seattle, WA
 - Fleet 81 Fern Ridge, Oregon

- VII North Central
 - Fleet 57 Columbus, Ohio

- VIII Central **Inactive**

- IX South Central
 - Fleet 40 Clear Lake, Texas

- XI Northeast **Inactive**

- X Southeast **Inactive**

Fleets (Historical)

Active fleets are underlined

<u>Fleet</u>	<u>Location</u>	<u>Fleet</u>	<u>Location</u>
1	<u>Newport Harbor, CA</u>	39	Western Carolina, SC
2	Marina Del Rey, CA	40	<u>Clear Lake, TX</u>
3	Lake Merritt, CA	41	Huntington Harbor, CA
4	Fresno, CA	43	Ventura, CA
5	Belvedere, CA	45	La Presa Grande (Chico, CA)
6	<u>Alamitos Bay, CA</u>	46	Long Island, NY
7	<u>Mission Bay, CA</u>	47	Monroe, Louisiana
8	Sacramento, CA	48	Vallejo, CA
9	<u>King Harbor, CA</u>	49	Foster City, CA
10	Palo Alto, CA	50	Pelican Yacht Club, Louisiana
11	Kern (Bakersfield), CA	52	Wonder Lake, IL
12	Pheonix, AZ	53	Coeur D'Alene
14	Coronado	54	Hoover Reservoir, Ohio
15	Lake Arrowhead, CA	55	South San Diego Bay, CA
16	Pomona Valley Sailing Assn.	57	<u>O'Shaugnessy Reservoir, Ohio</u>
17	San Diego, CA	58	Tahoe
18	Richmond, CA	59	<u>Morro Bay, CA</u>
19	Lake Merced, CA	60	Lake Arthur (Lafayette, Louisiana)
20	Santa Barbara, CA	61	Caprock Fleet of Lubbock, TX
20	Delaware Reservoir, Ohio	62	<u>Fremont, CA</u>
21	Oceanside, CA	63	Riverside, CA
22	Casper, WY	64	Amarillo, TX
23	Dallas, TX	65	Westlake Village, CA
24	Lake Quivira (Kansas City, KS)	66	Livermore, CA
25	<u>Portland, OR</u>	67	Austin, TX
26	Jackson, Mississippi	68	Tuscon, AZ
27	San Jose, CA	69	Las Vegas, NV
28	Arlington, TX	70	Rocky Fork Lake, Ohio
29	Buckeye Lake, Ohio	71	Santa Rosa, CA
30	Waco, TX	73	Dana Point, CA
31	Marion County, Kansas	74	Mission Viejo, CA
32	Lake Pontchartrain, Louisiana	76	Lake Oroville, CA
33	Birmingham, Alabama	77	<u>North Olympic, WA</u>
34	Seattle, WA	78	<u>Anacortes, WA</u>
35	Valle De Bravo, Mexico	79	<u>Utah</u>
36	<u>Rogue Valley (Oregon)</u>	80	<u>Seattle, WA</u>
37	Denver, Colorado	81	<u>Fern Ridge (Eugene, OR)</u>
38	Chicago, IL		

Member Roster - Alphabetical

<u>Member Name</u>	<u>Boat</u>	<u>Fleet</u>		
Abelman, Fred	3622	78	Davis, Peter	4048 7
Albright, Bob	4205	57	De La Garza, Teyo	4578 40
Allen, Charles	2445	40	De Bold, Patricia	Assoc.7
Bagby, Lynne	4238	59	Derosa, John	6104 1
Bailey, Ted	4847	57	Disher, Bob	81
Bankiewicz, Mike	5026	57	Doering, Joseph	4875 62
Barrett, Patrick	4151	78	Dooros, Dan	6088 6
Bartell, Renee	3515	1	Doyle, Brian	4483 1
Bateman, Jim	2166	6	Duoos, Dick	6037 77
Baumann, Mike	5058	6	Duthie, John	3901 59
Bell, Sam	1542	6	Eberly, Carl	6592 6
Benson, John	6004	59	Ericksen, Dick	3822 7
Betts, Stan	6041	7	Faillers, Stephanie	5100 1
Boertje, Dennis	6166	59	Ferramola, Gabriel	4827 6
Boudreaux, Greg	3650	1	Fey, Brett	80
Bovaird, Leslie	2862	40	Forquer, Jim	6048 1
Bowen, Marc	4932	25	Foster, Kent	4480 7
Brannin, Wayne	4554	6	Frangooles, Bob	3737 80
Bretschger, Peter	6163	1	Gammill, Roy	2761 59
Brew, Greg	2132	Unattached	Garlock, Tim	4283 80
Brown, Duncan	3720	25	Giddings, Ron	5060 59
Brown, Kevin	4532	6	Glade, Tom	3210 78
Brown, Margie	6006	6	Gonzales, Dianne	2853 6
Burdge, Don	5088	6	Good, Christopher	2309 7
Butler, Don	4524	77	Gordon, Gary	4390 62
Callender, Dave	2501	7	Gresham, John	4550 6
Campbell, Ken	4509	7	Hansen, Anne	1686 Unattached
Canny, Rick	6128	6	Hantke, Paul	4846 25
Canon, Terrie	6087	7	Harding, Mike	1815 40
Canty, Dennis	4568	80	Harris, Fred	3660 77
Caratan, Milan	273	Unattached	Hawken, Grey	6132 78
Carroll, Dave	3542	7	Heald, Chris	2223 81
Carroll, Jonathan	Assoc.	Unattached	Heisel, Carl	3731 25
Carson, Jeff	6187	80	Hendricks, Kenton	4585 59
Church, Stan	5030	6	Hendricks, Steve	4631 59
Clanton, Ron	2540	6	Henke, John	5036 7
Clark, Brian	4508	40	Hensley, Terence	4354 59
Collins, Chris	4602	Unattached	Hinshaw, Ted	4114 1
Compton, Sam	3945	40	Hinton, Roger	3906 7
Cover, Chuck	Assoc.	6	Hochart, Charlie	1072 7
Crisfield, Rick	3668	1	Hoover, Richard	4174 40
Crozier, Kevin	5033	62	Horswill, Joe	6201 59
D'Amico, Joe	6025	77	Howlett, Don	3910 40
Daubenberger, Joe	5110	77	Ispas, David	3391 81
Davidson, Clay	6010	25	Janney, Brian	6100 7
Davidson, Nancy	5127	1	Jefferson, Pete	Assoc.7
Davies, Roy	773	7	Jenkins, Thomas	4078 59
Davis, Joe H.	5121	62	Johns, Garrett	6009 78
			Johnson, TJ	4469 1

Joyce, Richard	3107	81	Romanini, Michael	2223	81
Kaltenbach, Eric	6197	1	Rosen, Mike	3141	57
Kip, Christopher	5040	Unattached	Rossen, Dan	1007	1
Kip, Grant	5040	Unattached	Rothenbuecher, Peter	3618	59
Kontra, Robert	6203	81	Runyan, Ron	3547	25
Koran, Rebecca	Assoc.7		Rygh, Pat	3000	59
Kownacki, Eric	6166	7	Salas, Larry	6051	59
Krokus, Don	2505	81	Salas, Steve	6053	25
Kunsman, Kerry	2843	7	Schaffel, Gary	3446	9
Land-Augustine, Anne	3101	7	Schoenrock, Gary	4279	78
Lee, Sidney	2317	62	Schoney, Travis	Junior	79
Leech, Bruce	4374	81	Serina, Don	6140	6
Leisure, Marr	2859	1	Sheppard, Daniel	1582	6
Lincoln, Kenneth	1963	77	Shlens, Debbie	6136	6
Livers, Pete	4399	Unattached	Siemer, Bob	4030	6
Lockwood, Don	5050	59	Sih, Brady	6188	1
Machado, Ed	3909	7	Simenz, Rod	6026	1
Marks, Frederick	4821	7	Sinclair, Jerry	2854	Unattached
Martin, Bob	4179	7	Skubi, Byron	6138	78
McCord, William	Assoc.1		Smith, Dave	3281	6
McDermaid, Jeff	6165	6	Spero, Bob	2707	9
McDonald, Bill	3857	57	St, Chuck	481	62
McGeevy, Thomas	2800	25	Stevens, Fred	2614	6
Mendoza, Jay	5116	1	Storms, Jim	3696	6
Michel, Butch	2665	62	Stults, Allan	1952	81
Miller, Al	4141	9	Sturm, Aaron	4819	7
Miller, Kaye	Junior	78	Svilicich, Mike	3072	6
Miller, Mark	3673	78	Switzer, Robert	3	6
Moentenich, Lorin	3997	25	Taughner, Donald	5024	6
Morrow, Kent	3622	78	Temple, Bud	6055	79
Navarra, Jack	4285	62	Thompson, Jim	989	6
Nolan, Sean	4013	40	Thorne, Gary	4865	1
Nugent, John	999	62	Tilton, Roger	6015	7
Orsini, Steve	6131	78	Tripp, Charles	1414	6
Orth, Jim	3111	59	Turigliatto, Jon	4834	6
Osborne, Richard	4613	79	Ullman, Dave	Assoc.1	
Ostic, William	Assoc.Unattached		Vizzini, Lisa	4061	77
Ostler, Mark	2831	57	Vowell, Jack	4955	59
Papadopoulos, John	6188	1	Walker, R. D.	Assoc.7	
Patterson, Roger	6127	7	Waterman, Maggie	5000	6
Perez, Al	5115	1	Watry, David H.	Assoc.7	
Peters, Thomas	4787	77	Way, George	Assoc.78	
Phillips, William	2577	6	Weinberger, Mark	3572	7
Polites, Pete	3139	57	Welch, Randy	2146	1
Porter, Dave	3804	6	Williams, Grant	4300	7
Potts, Dennis	4407	1	Williams, Paul	4391	1
Rand, Marvin	4111	9	Woolsey, Roy	4110	1
Richard, Dennis	2181	77	Yates, Bob	5051	1
Robertson, Stu	3113	7	York, T.L. Missy	5127	1
Rodgers, Gregory	4794	6			

FLEET 1 – NEWPORT HARBOR, CA

CAPTAIN: Randy Welch
SECRETARY: John Papadopoulos
TREASURER: Greg Boudreaux
MEASURER: Mark Gaudio
FLEET CHAMPION: Kurt Wiese

3515 Bartell, Renee Michael renee@bartells.com
3024 Ceylon Road, Costa Mesa, CA 92626 714/435-0874

3650 Boudreaux, Greg Michele gmboudreaux@west.raytheon.com
10122 Rangeview Drive, Santa Ana, CA 92705 714/505-0339

6163 Bretschger, Peter Kari pbretschger@intgmktg.com
27 Bluff View, Irvine, CA 92612 949/854-7404

3668 Crisfield, Rick Gayle
8432 Reilly Drive, Huntington Beach, CA 92646 714/536-1771

5127 Davidson, Nancy Gary ndavi@attbi.com
2535 Westminster Avenue, Costa Mesa, CA 92627 949/631-1160

6104 Derosa, John Dee john.a.derosa@rssmb.com
1701 Galatea Terrace, Corona del Mar, CA 92625 949/723-8292

4483 Doyle, Brian Kathleen brian.doyle@exult.net
501 Dahlia Avenue, Corona del Mar, CA 92625

5100 Faillers, Stephanie lido5100@adelphia.net
20242 Spruce Avenue, Newport Beach, CA 92663 949/863-1458

6048 Forquer, Jim Gwen forquer@cox.net
39 Vista Montemar, Laguna Niguel, CA 92677 949/495-4230

4114 Hinshaw, Ted Nell brinyman@ix.netcom.com
729 Via Lido Soud, Newport Beach, CA 92663 949/673-5001

4469 Johnson, TJ Mari Anna tj@healthinsuranceguru.com
607 Eleventh Street, Huntington Beach, CA 92648 714/960-5289

6197 Kaltenbach, Eric Candice ericjk@earthlink.net
11 Catania, Mission Viejo, CA 92692 949/855-4962

2859 Leisure, Marr Anne mleisure@cox.net
6 Bluff View, Irvine, CA 92612-3602 949/854-4491

Assoc. McCord, William wjmccord@aol.com
P. O. Box 460, Koloa, HI 96756 949/643-2990

5116	Mendoza, Jay	Betsey	jaymen@pacbell.net 949/699-0439
6188 5031	Papadopoulos, John		jakp@mindspring.com 949/863-1458
5115	Perez, Al	Rosemary	714/776-4696
4407	Potts, Dennis	Wendy Bell	dpotts@studley.com 949/644-1480
1007	Rossen, Dan		probchi@aol.com 949/673-3368
6188	Sih, Brady	Lusela	bsih@us.ibm.com 949/856-4313
6026	Simenz, Rod	Audrey	adrsmv@aol.com 949/462-0838
4865	Thorne, Gary	Karen	gary.thorne@eds.com 714/528-4646
Assoc.	Ullman, Dave		ullman@ullmansails.com 949/510-3317
2146	Welch, Randy		rwelch1@att.net 949/533-8127
4391	Williams, Paul	Etta	peask@aol.com 714/771-3149
4110	Woolsey, Roy	Louise	Roywoolsey@aol.com 949/673-3731
5051	Yates, Bob	Ellie	bobyates2@earthlink.net 949/673-3557
5127	York, T.L. Missy		myork@taa1.com 949/574-1325

FLEET 6 - ALAMITOS BAY, CA

CAPTAIN: Mike Baumann
SECRETARY: Kevin Brown
TREASURER: Ray Gonzales
MEASURER: Tracy Conn
FLEET CHAMPION: Freddie Stevens

2166	Bateman, Jim	Diane	jbateaux@aol.com
	188 Syracuse Walk, Long Beach, CA 90803		562/439-1190
5058	Baumann, Mike	Betty	bettymikeb@oco.net
	6062 Dagny Circle, Huntington Beach, CA 92647		714/840-8321
1542	Bell, Sam	Dana	sambell@prodigy.net
	5764 Campo Walk, Long Beach, CA 90803		562/438-4435
4554	Brannin, Wayne		e2teri@aol.com
	7836 Woodsboro Avenue, Anaheim, CA 92807		909/737-1300
4532	Brown, Kevin	Christina	kib@aol.com
	30324 Via Victoria, Rancho Palos Ver.,CA 90275		310/265-1103
6006	Brown, Margie	Don	slbrbrown@aol.com
	605 Sea Breeze Drive, Seal Beach, CA 90740		562/430-0258
5088	Burdge, Don	Trisia	don@burdge.com
	5601 Sorrento Drive, Long Beach, CA 90803		562/434-1776
6128	Canny, Rick		rick.canny@caltech.edu
	1615 Loma Vista Street, Pasadena, CA 91104		626/797-4555
5030	Church, Stan	Elise	stanelise@cox.net
	27435 Sunnyridge Road, Palos Verdes Pen.,CA 90274		310/377-8488
2540	Clanton, Ron	Carol	rc22540@netzero.net
	4242 Ladoga, Lakewood, CA 90713		562/425-1136
Assoc.	Cover, Chuck		
	5900 Naples Pl. #1, Long Beach, CA 90803		
6088	Dooros, Dan	Pam	
	833 Terraine Avenue, Long Beach, CA 90804		562/494-6562
6592	Eberly, Carl	Sheila	eber7376@aol.com
	6592 Glen Drive, Huntington Beach, CA 92647		714/896-0202
4827	Ferramola, Gabriel	Cheryl	gferramola@trcsolutions.com
	11632 Wembley Road, Los Alamitos, CA 90720		562/493-4931

2853	Gonzales, Dianne	Ray	lidochick1@yahoo.com
	2525 Ostrom Avenue, Long Beach, CA 90815		562/430-7318
4550	Gresham, John	Laura	john@gresham.com
	5846 Pavo Street, Long Beach, CA 90808		562/425-1986
6165	McDermaid, Jeff		captmac@earthlink.net
	1921 Park Street, Huntington Beach, CA 92648		714/536-7094
2577	Phillips, William	Vicki	bill.phillips@unistudios.com
	9532 Monaco Drive, Cypress, CA 90630		714/484-8965
3804	Porter, Dave	Beverly	porterdl@deltanet.com
	6066 San Rolando Way, Buena Park, CA 90620		714/828-8301
4794	Rodgers, Gregory		
	P. O. Box 1735, San Pedro, CA 90733		310/833-6878
6140	Serina, Don	Rachel	dserina@gte.net
	13349 Sutton Street, Cerritos, CA 90703		562/802-0123
1582	Sheppard, Daniel		rshepdan@aol.com
	5744 Snowden Avenue, Lakewood, CA 90713		562/867-0555
6136	Shlens, Debbie		shlensde@mattel.com
	19 Silver Spring Drive, Rolling Hills Est., CA 90274		310/378-4799
4030	Siemer, Bob	Stephanie	rseimer@charter.net
	63-64th Place, Long Beach, CA 90803		562/439-0505
3281	Smith, Dave	Jeanne	dandjsmith@earthlink.net
	12 Sirius, Irvine, CA 92616		949/725-9780
2614	Stevens, Fred	Alice	fs3cpa@aol.com
	105 Prospect, Long Beach, CA 90803		562/438-8354
3696	Storms, Jim		sce@ix.netcom.com
	4342 Katella Avenue, Los Alamitos, CA 90720		949/857-1874
3072	Svilicich, Mike		sillymon@hotmail.com
	2719 S. Cabrillo Ave. #3, San Pedro, CA 90731		310/832-4951
3	Switzer, Robert	Margaret	rlswitzer@seaside.net
	241 Euclid, Long Beach, CA 90803-6019		562/438-8109
5024	Taugher, Donald	Christine	taugher@gateway.net
	5291 Berkley Avenue, Westminster, CA 92683		714/893-0885
989	Thompson, Jim	Jenny James.Thompson2@west.boeing.com	
	51 La Verne Avenue, Long Beach, CA 90803		562/434-7227

1414	Tripp, Charles		chtripp@ci.long-beach.ca.us
	1414 Brett Place #225, San Pedro, CA 90732		310/548-3198
4834	Turigliatto, Jon		jturigliatto@cggdlawyers.com
	253 Nieto Avenue, Long Beach, CA 90803		562/439-1387
5000	Waterman, Maggie	Rob	maggiewaterman@excite.com
	21432 Fleet Lane, Huntington Beach, CA 92646		714/962-0480

FLEET 7 - MISSION BAY, CA

CAPTAIN:	Roger Hinton
SECRETARY:	Susan Betts
TREASURER:	Marilyn Patterson
MEASURER:	Grant Williams
FLEET CHAMPION:	Eric Kownacki

6041	Betts, Stan	Susan	sbetts1@san.rr.com
	2648 Nansen Avenue, San Diego, CA 92122-3120		858/455-6259
2501	Callender, Dave	Marilyn	callender@sbcglobal.net
	3204 Fosca Street, Carlsbad, CA 95014		760/942-9101
4509	Campbell, Ken	Sandyi	kencamp@spawar.navy.mil
	3960 Cypress Del Mar St., San Diego, CA 92130		858/755-6200
6087	Canon, Terrie		lidolady@pacbell.net
	1340 Hillview Ct., Carlsbad, CA 92008		760/434-8086
3542	Carroll, Dave	Barbara	davecarroll@antelecom.net
	2753 West Ave. N8, Palmdale, CA 93551		661/266-0368
773	Davies, Roy	Bonnie	roydavies@cox.net
	4339 Loma Del Sur, La Mesa, CA 91941		619/670-5015
4048	Davis, Peter	Patty	petepatty@worldnet.att.net
	11003 Negley Avenue, San Diego, CA 92131		858/695-0991
Assoc.	De Bold, Patricia		
	8870 Villa La Jolla Dr. #309, La Jolla, CA 92037		858/457-2845
3822	Ericksen, Dick	Bea	r.ericksen@worldnet.att.net
	1065 Calle Mesita, Bonita, CA 91902		619/475-1534
4480	Foster, Kent	Pam	kfoster@swgsgp.com
	815 Amiford Drive, San Diego, CA 92107		619/222-7792
2309	Good, Christopher	Sandy	chris@igood.com
	3083 McGraw Street, San Diego, CA 92117		858/270-4663

5036	Henke, John		juanflaco@hotmail.com
	4566-A Maryland Street, San Diego, CA 92116		619/298-8298
3906	Hinton, Roger	Anne	rwhinton@juno.com
	1006 Scott Street, San Diego, CA 92106		619/523-8479
1072	Hochart, Charlie	Barbara	chochar1@san.rr.com
	1937 Beryl Street, San Diego, CA 92109		858/273-7118
6100	Janney, Brian		bjanney@quantumsails.com
	4118 Catalina Pl., San Diego, CA 92107		619/226-4275
Assoc.	Jefferson, Pete	Barbara	hpjeffers@aol.com
	7725 Whitefield Place, La Jolla, CA 92037		858/459-9163
Assoc.	Koran, Rebecca		RAKoran@hotmail.com
	3245 James Drive, Carlsbad, CA 92008		760/729-0886
6166	Kownacki, Eric	Susan	eric@polarispool.com
	18674 Locksley Street, San Diego, CA 92128		858/487-3782
2843	Kunsman, Kerry	Peggy	kerryk@tns.net
	4742 Renex Place, San Diego, CA 92117		858/569-4877
3101	Land-Augustine, Anne	Michael	anne@san.rr.com
	7435 Ashford Place, San Diego, CA 92111		858/569-1767
3909	Machado, Ed	Zee	surfed@cox.net
	1055 Neptune Avenue, Encinitas, CA 92024		760/944-1300
4821	Marks, Frederick		fmmarks@aol.com
	10795 Escobar Drive, San Diego, CA 92124		858/505-0192
4179	Martin, Bob		romartin@cox.net
	5072 Avenida de la Plata, Oceanside, CA 92057		760/630-9145
6127	Patterson, Roger	Marilyn	lidopatt@san.rr.com
	2476 Baja Cerro Circle, San Diego, CA 92109		858/270-0177
Assoc.	Walker, R. D.	Gail	rdgail@nethere.com
	4381 Shasta Place, Carlsbad, CA 92008		760/729-6034
3113	Robertson, Stu	Bonnie	
	16212 Brimhall Lane, Huntington Beach, CA 92547		714/846-4220
4819	Sturm, Aaron	Laureen	aaronsturm@msn.com
	4417 Upland Street, La Mesa, CA 91941		619/741-6989
6015	Tilton, Roger	Pat	r.p.tilton@earthlink.net
	826 Devon Court, San Diego, CA 92109		858/488-0995

Assoc.	Watry, David H.	Barbara	bwatry@sciti.com
	2104 Blackmore Court, San Diego, CA 92109		858/272-2532
3572	Weinberger, Mark	Lisa	servpro8724@adelphia.net
	1539 Madrid Drive, Vista, CA 92083		760/727-8910
4300	Williams, Grant	Barbara	bwilliam@san.rr.com
	1101 Van Nuys Street, Pacific Beach, CA 92109		858/488-4424

FLEET 9 - KING HARBOR, CA

CAPTAIN: Al Miller
 SECRETARY:
 TREASURER:
 MEASURER:
 FLEET CHAMPION:

4141	Miller, Al	Lilli	
	4658 Fulton Avenue, Sherman Oaks, CA 91423		818/784-5741
4111	Rand, Marvin	Mary Ann	
	1310 Abbot Kinney Blvd., Venice, CA 90291		310/396-3441
3446	Schaffel, Gary	Diane	gary@schaffeldev.com
	3721 Via Dolce, Marina Del Rey, CA 90292		310/823-2001
2707	Spero, Bob	Hermi	
	18609 Superior Street, Northridge, CA 91325-1952		818/701-1422

FLEET 25 - PORTLAND, OR

CAPTAIN: Ron Runyan
 SECRETARY: Steve Salas
 TREASURER: Steve Salas
 MEASURER: Lorin Moentenich
 FLEET CHAMPION: Carl Heisel

4932	Bowen, Marc	CeCe	marc@marcbowenproductions.com
	P. O. Box 9163, Portland, OR 97207		503/295-3641
3720	Brown, Duncan		matteibrown@attbi.com
	2934 NE 29th Avenue, Portland, OR 97212		503/288-1750
6010	Davidson, Clay	Elizabeth	clay@CaseDavidson.com
	17374 Lake Haven Drive, Lake Oswego, OR 97035		503/635-7475
4846	Hantke, Paul	Maryann	pandm@teleport.com
	2541 SW Taylors Ferry Rd., Portland, OR 97219		503/244-5093

3731	Heisel, Carl	Lia	cheisel1@msn.com
	5810 SW Luradel Court, Portland, OR 97219		503/245-2681
2800	McGeevy, Thomas	Jennifer	thomas.a.mcgreevy@intel.com
	2575 SW Custer Street, Portland, OR 97219		503/696-8868
3997	Moentenich, Lorin	Avis	
	2608 SE 37th Avenue, Portland, OR 97202		503/232-2838
3547	Runyan, Ron	Nicole	ron@runyans.com
	10026 SW Quail Post Road, Portland, OR 97219		503/246-7538
6053	Salas, Steve	Breah	smsalas@concentric.net
	1745 SE Clatsop Street, Portland, OR 97202		503/239-7110

FLEET 40 - CLEAR LAKE, TX

CAPTAIN: Richard Hoover
 SECRETARY: Charles Allen
 TREASURER: Richard Hoover
 MEASURER: Teyo De La Garza
 FLEET CHAMPION: Don Howlett

2445	Allen, Charles		L14Pirate@evl.net
	50 David Road #D201, League City, TX 77573		281/557-2082
2862	Bovaird, Leslie	Linda	DolfinFish@aol.com
	654 Warsaw Street, Bayou Vista, TX 77563-2606		409/908-0037
4508	Clark, Brian	Wendy	bclark@slb.com
	86 Greensward Lane, Sugar Land, TX 77479		281/565-7698
3945	Compton, Sam	Ginny	samginny@yahoo.com
	1003 Patsy, Baytown, TX 77520		281/428-1186
4578	De La Garza, Teyo	Mary	teyo@swbell.net
	16219 Longvale, Houston, TX 77059		281/488-3921
1815	Harding, Mike	Tina	mharding@paraengr.com
	11322 Verlaile Dr., Houston, TX 77065		281/955-5178
4174	Hoover, Richard	Paula	rubberduck@mcleodusa.net
	2008 McKissick Drive, Friendswood, TX 77546		281/996-7716
3910	Howlett, Don	Sue	donhowlett@aol.com
	1401 Walnut, Kingwood, TX 77339		281/358-6288
4013	Nolan, Sean	Shawna	tingod@mindspring.com
	306 Queen, Clear Lake Shores, TX 77565		281/538-5381

FLEET 57 - LEATHERLIPS Y.C., O'SHAUGNESSY RESERVOIR, OH

CAPTAIN: Bob Albright
SECRETARY:
TREASURER: Ted Bailey
MEASURER:
FLEET CHAMPION:

4205	Albright, Bob	Barbara	
	185 Blenheim Road, Columbus, OH 43214		614/262-0440
4847	Bailey, Ted	Janet	baileyled@msn.com
	3012 Scioto Place, Columbus, OH 43221		614/771-0358
5026	Bankiewicz, Mike	Dorthy	cisban@myexcel.com
	965 Garden Road, Columbus, OH 43221		614/262-4111
3857	McDonald, Bill	Marybeth	willennium@aol.com
	2517 Slateshire Drive, Dublin, OH 43016		614/764-4573
2831	Ostler, Mark	Julie	mostler@columbus.rr.com
	5060 Greensboro Court, Columbus, OH 43220		614/451-7313
3139	Polites, Pete	Virginia	peterpolites@hotmail.com
	1632 Bryden Road, Columbus, OH 43205		614/253-5600
3141	Rosen, Mike	Blanca	clararosen@msn.com
	778 South 6th Street, Columbus, OH 43206		614/449-8134

FLEET 59 - MORRO BAY, CA

CAPTAIN: Tom Jenkins
SECRETARY: Kit Lockwood
TREASURER: Kit Lockwood
MEASURER: Don Lockwood
FLEET CHAMPION: Tom Jenkins

4238	Bagby, Lynne	Dinah	PalmTag@gte.net
	525 Ramona Avenue, Los Osos, CA 93402		805/528-0871
6004	Benson, John	Patricia	
	1130 Garden Street, Ste. C, San Luis Obispo, CA 93401		
6166	Boertje, Dennis	Rosemarie	dboertje@aol.com
	3742 W. Coppola Avenue, Visalia, CA 93277		559/625-1953
3901	Duthie, John	Christy	
	373 Los Osos Valley Road, Los Osos, CA 93402		805/528-4704

2761	Gammill, Roy	Beverly	rgammill@fix.net
	2536 Nutmeg, Morro Bay, CA 93442		805/772-4840
5060	Giddings, Ron	Susan	rands@fix.net
	1625 Ninth Street, Los Osos, CA 93402		805/528-1777
4585	Hendricks, Kenton		kman45@jps.net
	9811 Atascadero Avenue, Atascadero, CA 93422		805/466-2481
4631	Hendricks, Steve	Tamara	kman45@jps.net
	9811 Atascadero Avenue, Atascadero, CA 93422		805/466-2481
4354	Hensley, Terence	terry.hensley@liggett-emh1.army.mil	
	P. O. Box 892, Jolon, CA 93928-0892		831/386-2050
6201	Horswill, Joe	Rhonda	jlhorswill@TulareEsq.com
	1129 Valley Forge, Tulare, CA 93274		559/686-3861
4078	Jenkins, Thomas	Bette	th11688@aol.com
	P. O. Box 151, Arroyo Grande, CA 93421		805/489-1832
5050	Lockwood, Don	Kit	dlockwoo@fix.net
	140 Luzon Street, Morro Bay, CA 93442		805/772-3994
3111	Orth, Jim	Sarah	sjorth@lemoocenet.com
	2133 N. Tenth Avenue, Hanford, CA 93230		559/584-5853
3618	Rothenbuecher, Peter	Anita	atascaderocarpet@thegrid.net
	5225 El Camina Real, Atascadero, CA 93422		805/466-3100
3000	Rygh, Pat	Dot	pjrygh@aol.com
	372 Travis Drive, Los Osos, CA 93402		805/528-8107
6051	Salas, Larry	Liz	ccoastwelcome@charter.net
	54 Benton Way, San Luis Obispo, CA 93405		805/541-2801
4955	Vowell, Jack (dec.)	Joan	jvowell@fix.net
	909 Calle Cynthia, Atascadero, CA 93422		805/461-6559

FLEET 62 - FREMONT, CA

CAPTAIN: Chuck St. Denis
SECRETARY: Linda Gordon
TREASURER: Linda Gordon
MEASURER: Joe Davis
FLEET CHAMPION: Joe Doering

5033	Crozier, Kevin	Catherine	kmcrozier@yahoo.com 510/791-0243
	39270 Paseo Padre Pky.231, Fremont, CA 94536		
4875	Doering, Joseph	Cathy	lido4875@attbi.com 510/793-5578
	3110 Dunsaney Court, Fremont, CA 94536		
4390	Gordon, Gary	Linda	garlind77@aol.com 510-796-4299
	1384 Gilbert Avenue, Fremont, CA 94536		
5121	Davis, Joe H.		jdavis@divi.com 510/790-8933
	35751 Caxton Ct., Fremont, CA 94536		
2317	Lee, Sidney	Doris	sidney.lee@seagate.com 408/360-9327
	5320 Wong Ct. #144, San Jose, CA 95123		
2665	Michel, Butch	Kathy	KMM4RPM@aol.com 209/551-2813
	2009 Boston Way, Modesto, CA 95355		
4285	Navarra, Jack	Carolyn	JCNAVARRA@aol.com 510/656-0258
	4949 Valpey Park, Fremont, CA 94538		
999	Nugent, John	Wendy	jfnugent@cats.ucsc.edu 831/475-3299
	664 Paget Street, Santa Cruz, CA 95062		
481	St. Denis, Chuck	Karen	FSCLIDO@aol.com 408/263-5690
	820 Pheland Court, Milpitas, CA 95035		

FLEET 77 – NORTH OLYMPIC, WA

CAPTAIN: Lisa Vizzini
SECRETARY: Kenneth Lincoln
TREASURER: Dick Duoos
MEASURER: Joe D'Amico
FLEET CHAMPION:

4524	Butler, Don	Noelle	butler@olympen.com 360/683-9443
	71 Garden Lane, Sequim, WA 98282		
6025	D'Amico, Joe	Carol	joedamico@olympus.net 360/681-0754
	122 Marshall Road, Sequim, WA 98382		

5110	Daubenberger, Joe	Julie Ann	joed@olyphen.com
	3001 Alder Street, Port Townsend, WA 98368		360/385-5345
6037	Duoos, Dick	Janice	duoos@cablespeed.com
	P. O. Box 65312, Port Ludlow, WA 98365		360/437-9361
3660	Harris, Fred	Sandy	sanfred@cablespeed.com
	63 Foxfield Drive, Port Townsend, WA 98368		360/385-7861
1963	Lincoln, Kenneth		klincoln@olympus.net
	P. O. Box 1631, Port Townsend, WA 98368		360/385-2376
4787	Peters, Thomas	Polly	tpeters@olympus.net
	714 Olympic Ridge Drive, Port Ludlow, WA 98365		360/437-2493
2181	Richard, Dennis	Amy	drichard@olyphen.com
	342 Shuksan Ridge Road, Sequim, WA 98382		360/683-2803
4061	Vizzini, Lisa		ptriging@olyphen.com
	1201 Wilson Street, Port Townsend, WA 98368		360/385-4347

FLEET 78 - "PIG-IN-A-POKE FLEET" ANACORTES, WA

CAPTAIN: George Way
 SECRETARY: - none -
 TREASURER: Ginger Orsini
 MEASURER:
 FLEET CHAMPION: Gary Schoenrock

3622	Abelman, Fred	Bobbi	acon@fidalgo.net
	1211 "B" Avenue, Anacortes, WA 98221		360/293-9444
4151	Barrett, Patrick	Meredith	patbarrett@attbi.com
	11987 Marine Drive, Anacortes, WA 98221		360/293-9377
3210	Glade, Tom	Kay	tglade@pacar.com
	6567 Deer Lane, Anacortes, WA 98221		360/293-2431
6132	Hawken, Grey	Carolyn	frodog@nwlink.com
	14754 Lexington Avenue, Anacortes, WA 98221		360/293-2202
6009	Johns, Garrett		gwjohns@yahoo.com
	209 N. Hawthorne Street, Burlington, WA 98233-1605		360/755-1615
Junior	Miller, Kaye		
	5850 Buttram Lane, Anacortes, WA 98221		
3673	Miller, Mark		indigo@fidalgo.net
	5850 Buttram Lane, Anacortes, WA 98221		360/293-1243

3622	Morrow, Kent	Gina	downeast@cnw.com
	4805 Harbor View Place, Anacortes, WA 98221		360/293-4342
6131	Orsini, Steve	Ginger	sorsini@ncia.com
	1213-1/2 14th Street, Anacortes, WA 98221		360/293-1151
4279	Schoenrock, Gary	Carolyn	slice13551@hotmail.com
	13551 Slice Street, Anacortes, WA 98221		360/293-8807
6138	Skubi, Byron	Jane	kbskubi@hotmail.com
	1279 W. Penn Cove Road, Oak Harbor, WA 98277		360/675-1137
Assoc.	Way, George		grway@fidalgo.net
	319-5th Street, Anacortes, WA 98221		360/293-7305

FLEET 79 - UTAH

CAPTAIN: Rich Osborne
 SECRETARY:
 TREASURER:
 MEASURER:
 FLEET CHAMPION:

4613	Osborne, Richard		osborne@oco.net
	P. O. Box 366, Salt Lake City, UT 84110		801/363-4029
Junior	Schoney, Travis		h2oline@earthlink.net
	10876 Pleasant Hill Drive, Sandy, UT 84092		801/576-1764
6055	Temple, Bud		budtemple@cs.com
	2447 South 800 East, Salt Lake City, UT 84106		801/474-1709

FLEET 80 - SEATTLE, WA

CAPTAIN: Tim Garlock
 SECRETARY: Bob Frangooles
 TREASURER: Anne Pace
 MEASURER: Jeff Carson
 FLEET CHAMPION:

4568	Canty, Dennis		dcanty@evergreenfc.com
	404 NW 60th Street, Seattle, WA 98107		206/782-2557
6187	Carson, Jeff	Marcia	jcarson@microsoft.com
	11019 Patten Lane SW, Vashon, WA 98070		206/567-5782
	Fey, Brett		bfey@microsoft.com
	715 N. 48th Street, Seattle, WA 98103		206/604-3585

3737	Frangoles, Bob	Anne Pace	bob.frangoles@attws.com
	16806 SE 2nd Place, Bellevue, WA 98008		425/644-5337
4283	Garlock, Tim	Lori	lgarlock@prodigy.net
	5241 42st Ave. SW, Seattle, WA 98136		

FLEET 81 – FERN RIDGE, OR

CAPTAIN:	Don Krokus
SECRETARY:	Richard Joyce
TREASURER:	Richard Joyce
MEASURER:	Ron Fish
FLEET CHAMPION:	- none -

Disher, Bob	Kim	scootercanooter@aol.com
1821 SW Boxwood Lane, Dallas, OR 97338		503/623-2674

2223	Heald, Chris		
	1645 Roosevelt St. NE, Salem, OR 97303		503/364-9474

3391	Ispas, David	Patty	ispasd@proaxis.com
	3930 NW Tillicum Pl., Corvallis, OR 97330		541/740-3996

3107	Joyce, Richard	Kathy	
	36279 Middleridge Drive, Lebanon, OR 97355		541/451-4893

6203	Kontra, Robert	Deborah	BDKontra@aol.com
	1727 NW Embassy Place, Albany, OR 97321-1209		541/924-9472

2505	Krokus, Don		
	723 Chestnut Avenue, Cottage Grove, OR 97424		541/942-6918

4374	Leech, Bruce	Pat	soapcr@proaxis.com
	37243 Moss Rock Drive, Corvallis, OR 97330		541/715-2193

2223	Romanini, Michael		mmromanini@yahoo.com
	2348 Church St. SE, Salem, OR 97302		503/364-9642

1952	Stults, Allan	Patty	astults@lane.k12,or.us
	25285 Perkins Road, Veneta, OR 97487		541/935-0344

UNATTACHED MEMBERS

2132	Brew, Greg	Rexann	gregcbrew@earthlink.net 310/293-1360
	788 No. Catalina Avenue, Pasadena, CA 91104		
273	Caratan, Milan	Judith	milac@bak.rr.com 661/725-2566
	7805 Calle Nobleza, Bakersfield, CA 93309		
Assoc.	Carroll, Jonathan		
	2753 West Ave. N8, Palmdale, CA 93551		
4602	Collins, Chris	Ann Marie	ccollsail@aol.com 818/842-3667
	23930 Via Onda, Valencia, CA 91355		
1686	Hansen, Anne		CM14113@alltel.net 402/434-7152
	9100 S. 70 Street, Lincoln, NE 68516		
5040	Kip, Christopher	Jo Ann	CLKip@aol.com 661/269-2934
	3722 Gurrier Avenue, Acton, CA 93510-1942		
5040	Kip, Grant		661/269-4407
	3722 Gurrier Avenue, Acton, CA 93510-1942		
4399	Livers, Pete		livek2@aol.com 541/482-6004
	475 N. Main St. #2, Ashland, OR 97520		
Assoc.	Ostic, William	Anneli	wostic@yahoo.com 714/633-8848
	2720 E. Walnut Ave. #47, Orange, CA 92867		
2854	Sinclair, Jerry	Elaine	windwest@pacbell.net 714/779-6736
	2707 Saturn Street, Brea, CA 92821		

2002 CLASS CHAMPIONSHIPS

Sequim Bay, Washington

August 11-15, 2002

Sponsored by Lido 14 Fleet 77 (North Olympic Fleet)
and Sequim Bay Yacht Club

Gold Fleet

- 1st Mark Gaudio & John Papadopoulos
- 2nd Bob Yates & Pat Kincaid
- 3rd Eric & Alexa Kownacki
- 4th Freddie & Fred Stevens
- 5th Roger Patterson & Kathy Allen
- 6th Joe Daubenberger & Jon Piskula
- 7th Grant & Barbara Williams
- 8th Carl & Kelly Heisel
- 9th Don Butler & Dennis Richard
- 10th Spencer Snapp & Lisa Vizzini

Silver Fleet

- 1st Garrett Johns & Don Depew
- 2nd Ron & Nicole Runyon
- 3rd Roger & Anne Hinton
- 4th Joe D'Amico & Ruth Pence
- 5th Rich Osborne & Stephanie Carroll



**W.D. Schock Trophy
Class Champion**



**2002 Class Champions
John Papadopoulos(L) and Mark Gaudio (R) with
President Carroll presenting**

Class Champions

<u>Year</u>	<u>Class Champion</u>	<u>Crew</u>	<u>Championship Venue</u>
2002	Mark Gaudio	John Papadopoulos	Sequim Bay, Washington
2001	Mark Gaudio	Doug McLean	Huntington Lake, California
2000	Nick Scandone	Dustin Arnold	Big Bear Lake, California
1999	John Papadopoulos	Stephanie Failers	Howard Prairie Lake, Oregon
1998	Nick Scandone	Phil Freeman	Mission Bay, California
1997	George Szabo	Jeff Baker	Huntington Lake, California
1996	George Szabo	Stacey Dumain	Sequim Bay, Washington
1995	Craig Leweck	Jeff Baker	Big Bear Lake, California
1994	Chris Raab	Rob Lindley	Mission Bay, California
1993	Craig Leweck	Greg Reynolds	Newport Beach, California
1992	Craig Leweck	Alex Phillips	Big Bear Lake, California
1991	Charlie Cummings	Tom Devlin	Mission Bay, California
1990	Craig Leweck	Robyn Garrison	Yale Lake, Washington
1989	Craig Leweck	Brett Davis	Huntington Lake, California
1988	Chris Raab	Rob Lindley	King Harbor, California
1987	Tim Mulvaney	Rick Peck	Buckeye Lake, Ohio
1986	Dave Ullman	Kenny Watts	Huntington Lake, California
1985	Charlie Cummings	Tom Devlin	Mission Bay, California
1984	Charlie Cummings	Tom Devlin	Yale Lake, California
1983	Jack Franco	Renee Vesterby	Donner Lake, California
1982	Dave Ullman	Mark Whitehouse	Newport Beach, California
1981	Jack Franco	Kris Schrower	Dallas, Texas
1980	Chris Raab	David Swain	King Harbor, California
1979	Chris Raab	David Swain	Mission Bay, California
1978	Dave Ullman	Kenny Watts	Huntington Lake, California
1977	Dave Ullman	Danny Thompson	Clear Lake, California
1976	Dave Ullman	Ross Buthcher	Houston, Texas
1975	Stu Robertson	Rob Nelson	Alamitos Bay, California
1974	Pete Jefferson	Sylvia Jefferson	Yale Lake, Washington
1973	Pete Jefferson	Sylvia Jefferson	King Harbor, California
1972	Dave Ullman	Gary Hamilton	Club de la Pena, Mexico
1971	Dave Ullman	David Riley	Mission Bay, California
1970	Dave Ullman	Danny Thompson	Jackson, Mississippi
1969	Dave Ullman	Dave White	Newport Beach, California
1968	Ed Rodriguez	Flo Rodriguez	Huntington Lake, California
1967	Harry Wood	Dayle Wood	Eugene, Oregon
1966	Harris Hartman	Natalie Hartman	Mission Bay, California
1965	Harry Wood	Dayle Wood	Fort Worth, Texas
1964	Ed Rodriguez	Flo Rodriguez	King Harbor, California
1963	Mike Hirsh	Valerie Wilde	Lake Merritt, California
1962	Harry Wood	Jackie Wood	Newport Beach, California
1961	Mike Hirsh	Valerie Wilde	Alamitos Bay, California
1960	Stan Miller	- unknown -	Newport Beach, California
1959	Mike Hirsh	- unknown -	Newport Beach, California
1958	Phelps Merickel	- unknown -	Newport Beach, California

Warren F. Pomeroy Memorial Trophy

Winner of 1st Gold Flight Race
in the Class Championships

2002 Roger Patterson & Kathy Allen
2001 Mark Gaudio & Doug McLean
2000 Tony Beltran & Adam Himelson
1999 Kurt & Evelyn Wiese
1998 Nick Scandone & Phil Freeman
1997 Stu Robertson
1996 George Szabo & Stacey Dumain
1995 Craig Leweck & Jeff Baker
1994 Mark Gaudio & Erik Kingaard
1993 Craig Leweck & Greg Reynolds
1992 Craig Leweck & Alex Phillips
1991 Don Barrus
1990 Charlie Cummings
1989 Craig Leweck
1988 Craig Leweck
1987 Tim Mulvaney
1986 David Ullman
1985 Chris Raab
1984 Charlie Cummings
1983 Jack Franco
1982 Jack Franco & Kris Schrower
1981 Jack Franco
1980 Chris Raab
1979 Chris Raab
1978 David Ullman
1977 Stu Robertson
1976 David Ullman
1975 Stu Robertson
1974 Stu Robertson
1973 Ed Rodriguez
1972 David Ullman
1971 David Ullman
1970 Gib Marshall
1969 Pete Jefferson
1968 Tom Leweck
1967 Harry Wood
1966 Ed & Flo Rodriguez
1965 Harry & Dayle Wood
1964 Ed Rodriguez
1963 Row Lowman
1962 Phil Glasgow
1961 Mike Hirsh



**Kathy Allen (L), President David Carroll,
and Roger Patterson (R)**

President's Trophy

Winner of 2nd Gold Flight Race
in the Class Championships

2002	Mark Gaudio & John Papadopoulos
2001	Bob Yates & Pat Kincaid
2000	Stu Robertson & Cameron Biehl
1999	Tom & Bette Jenkins
1998	George Szabo & Jeff Baker
1997	Stu Robertson
1996	George Szabo & Stacey Dumain
1995	Craig Leweck & Jeff Baker
1994	Chris Raab
1993	Mark Gaudio & Erik Kingaard
1992	Craig Leweck & Alex Phillips
1991	John Jackman
1990	Charlie Cummings
1989	Craig Leweck
1988	David Carroll
1987	Tim Mulvaney
1986	David Ullman
1985	Chris Raab
1984	Charlie Cummings
1983	Jack Franco
1982	Dave & Barbara Carroll
1981	Jack Franco
1980	Chris Raab
1979	Chris Raab
1978	David Ullman
1977	Stu Robertson
1976	David Ullman
1975	Stu Robertson
1974	Stu Robertson
1973	Ed Rodriguez
1972	David Ullman
1971	David Ullman
1970	Gib Marshall
1969	Pete Jefferson
1968	Tom Leweck
1967	Harry Wood
1966	Ed & Flo Rodriguez
1965	Marty Lockney & Cal Preston
1964	Ed Rodriguez
1963	Row Lohman
1962	Phil Glasgow
1961	Mike Hirsh



Governing Board Trophy
Winner of 3rd Gold Flight Race
in the Class Championships

2002 Mark Gaudio & John Papadopoulos
2001 Mark Gudio & Doug McLean
2000 Nick Scandone & Dustin Arnold
1999 Mike Pinckney & Jamie DeWolfe
1998 Chris Raab
1997 George Szabo & Jeff Baker
1996 Don Barrus & Dave Porter
1995 Chris Raab & Rob Lindley
1994 Craig Leweck
1993 Dave Ullman & Kurt Mayol
1992 Kent Foster
1991 John Jackman
1990 - Race Cancelled -
1989 Dave Ullman
1988 Chris Raab
1987 David Carroll
1986 Kent Foster
1985 Chris Raab
1984 Charles Cummings
1983 Chuck VanDeventer
1982 Guy Raffee & Brian Peugh
1981 Charles Cummings
1980 Charles Cummings
1979 Lou Brooks
1978 Dave Ullman
1977 Dave Ullman
1976 Tom Linskey
1975 John Thorne
1974 Pete Jefferson
1973 Ed Rodriguez
1972 Dave Ullman
1971 Dave Ullman
1970 Bert Keenen
1969 Dick Lineberger
1968 Bill McCord
1967 Gib Marshall
1966 Ed & Flo Rodriguez
1965 Marty Lockney & Cal Preston
1964 Marty Lockney
1963 Stan Miller
1962 Harry Wood



Fleet 2 Trophy

Winner of Silver Flight
in the Class Championships

2002	Garrett Johns & Don Depew
2001	Jim & Kay Sterner
2000	Dave & Jeanne Smith
1999	Roger Patterson & Kathy Allen
1998	Lenore Collins & Katie Prigmore
1997	Gib Marshall & Erin Fernand
1996	Dobby Daubenberger
1995	Joe Doering
1994	Greg & Nancy Cotton
1993	Roger & Pat Tilton
1992	Blair Bryant
1991	Gabe Ferramola
1990	Blair Bryant
1989	Patrick Kincaid
1988	Wayne Hatch
1987	Ed Coughlin
1986	Thad Vincent
1985	Tim Mulvaney
1984	Bob Ucciferri
1983	Kirk Tobler
1982	Row & Bonnie & Vicki Lohman
1981	Bob Jump
1980	Ken Campbell
1979	Bruce Bear
1978	John Marion
1977	Don Stoughton
1976	Dario Sanchez
1975	Jack McClarty
1974	Joe DeBold & Judy Prell
1973	John C. Palmer
1972	Kelly Snow
1971	Mike Fink
1970	
1969	Tom Conerly
1968	John Peters
1967	Angus Lee
1966	Roy Woolsey



Team Trophy

Teams are created by pairing boats after the Gold Fleet qualification round of the Senior Class Championships; the first Gold Fleet boat is paired with the last Silver Fleet boat, the second Gold Fleet boat with the next to last Silver Fleet boat, etc Each team's score is the sum of both boats scores; the team with the lowest overall score is awarded the Team Trophy. The purpose of this trophy is to encourage Gold Fleet members to educate and improve the sailing skills of their teammates. Kit Lockwood (Fleet 59 - Morro Bay, CA) conceived the Team Trophy concept and Paul Williams (Fleet 1 - Newport Harbor, CA) built the trophy. The trophy was first awarded in 1996 in Sequim Bay, Washington.

2002	Spencer Snapp/Lisa Vizzini & Garrett Johns/Don Depew
2001	Tom Jenkins/Bette Jenkins & John Nugent/Chuck Quinn
2000	Nick Scandone/Dustin Arnold & Roger Tilton/Pat Tilton
1999	Mike Pinckney/Jamie DeWolfe & Tom Glade/George Way
1998	Chris Raab & Roy Woolsey
1997	Kurt Wiese & Larry Salas
1996	Don Barrus/Dave Porter & Dick Duoos

Betty Schock Perpetual Trophy

First Women Skipper
in the Class Championships

2002	- Not Awarded -
2001	Terry Smith & Mary Niederberger
2000	Susie Denny
1999	- Not Awarded -
1998	Dianne Gonzalez & Ray Gonzales
1997	Lenore Collins & Katie Prigmore
1996	Lorena Cobl & Roger Coble
1995	Marty Bowman & Greg Boudreaux
1994	Nancy Grubbs
1993	Molly Choate & Amber Morrow
1992	Marty Bowman & Shirley Smith
1991	Ruth Paulling
1990	Leslie Osmera-Rock
1989	Vicki Lohman Thompson
1988	Marty Bowman & Shirley Smith
1987	Jackie Harkowitz
1986	Vicki Lohman Kazmer



Jim Tyler Trophy

First Family to Finish in the Class Championships

2002	Eric & Alexa Kownacki
2001	Tom & Bette Jenkins
2000	Tom & Bette Jenkins
1999	Tom & Bette Jenkins
1998	Jeff & Becky Lenhart
1997	Stu & Erin Robertson
1996	Kent & Chris Foster
1995	Gabe & Cheryl Feramola
1994	Jeff & Becky Lenhart
1993	Gary & Karen Thorne
1992	Kent Foster & Pam Fairley
1991	Kent Foster & Pam Fairley
1990	Kent Foster & Pam Fairley
1989	Keith & Claudia Dodson
1988	Dave & Barbara Carroll
1987	Kent Foster & Pam Fairley
1986	Kent Foster & Pam Fairley
1985	Hal Brown & Debbie Krebs
1984	Kent Foster & Pam Fairley
1983	Bill & Sandra Denhart
1982	Pete & Sylvia Jefferson
1981	Bill & Sandra Denhart
1980	Argyle & Penny Campbell
1979	Charlie & Gay Cummings



**First Family Winners
Alexa & Eric Kownacki**

Grand Master Trophy
First Skipper Over 50
in the Class Championships

2002 Bob Yates & Pat Kincaid
2001 Bob Yates & Pat Kincaid
2000 Bob Yates & Pat Kincaid
1999 Kent & Chris Foster
1998 Jeff Lenhart
1997 Bob Yates
1996 Don Barrus & Dave Porter
1995 Bob Yates
1994 Jeff Lenhart
1993 Gib Marshall
1992 Chuck Babcock
1991 Gib Marshall
1990 Gib Marshall
1989 Ed Rodriguez
1988 David Carroll
1987 Ed Rodriguez
1986 Ed Rodriguez
1985 Row Lohman
1984 Wayne Hatch
1983 Pete Jefferson
1982 Pete Jefferson
1981 Pete Jefferson
1980 Pete Jefferson
1979 Bill McCord
1978 Pete Jefferson
1977 Pete Jefferson
1976 Pete Jefferson
1975 Pete Jefferson
1974 Gib Marshall
1973 Ed Rodriguez
1972 Beach Riley
1971 Merlin Gayman
1970 - not awarded -
1969 Chad Twichell
1968 - not awarded -
1967 Don Robertson



Bob Yates (R) and Pat Kincaid (L)

**Hike hard
Sail fast
Have fun**



Ullman Sails has been building championship winning sails for Lido 14's since 1969.
We work hard to give you the fastest sails and best service.

ULLMAN SAILS

410-29th Street • Newport Beach, CA 92663
949-675-6970 • FAX 949-675-6276

www.ullmansails.com • ullman@ullmansails.com

*Jamie DeWolfe and Adrienne Patterson
working hard at the Junior Nationals*

Photo credit: DoubleWare

Gresham Boards

Custom Centerboards and Rudders

"Ultra Light and Fast"

562-756-7600

GreshamBoards.com

Lido 14 Class Sloop Approved Racing Measurements

DO NOT SCALE

Revised March, 2002, dlc Drawing original on Autosketch V 7.0
 Revised April 19, 2002, jap Cleanup. Revised notes. Added hull#
 Revised June 25, 2002, dlc/jap Cleanup. CB LE to Transom dim.

CENTERBOARD DETAIL

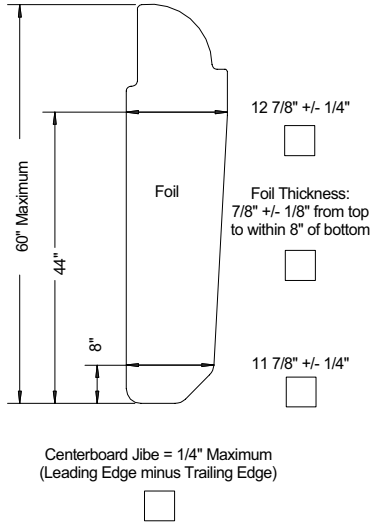

- NOTES:
1. Maximum length is 60" excluding fittings and hangers.
 2. Maximum thickness is 1" except trailing edge at keel (A/C # 54).
 3. Essential dimensions are measured without removing the board.
 4. Chord dimensions are perpendicular to the leading edge at 8" and 44" locations from the tip.
 5. Shape of bottom 8" is unrestricted.

BRIDLE-TRAVELER / TRANSOM DETAIL

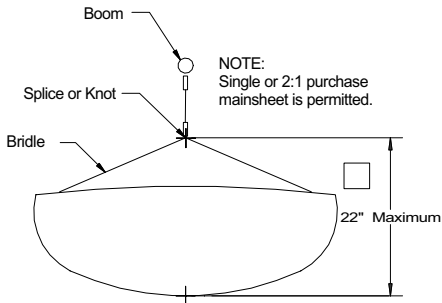

RUDDER DETAIL

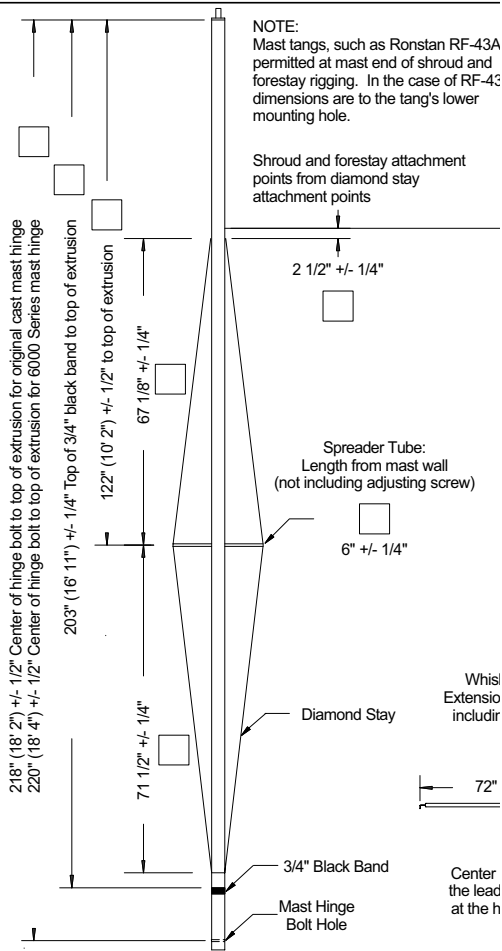
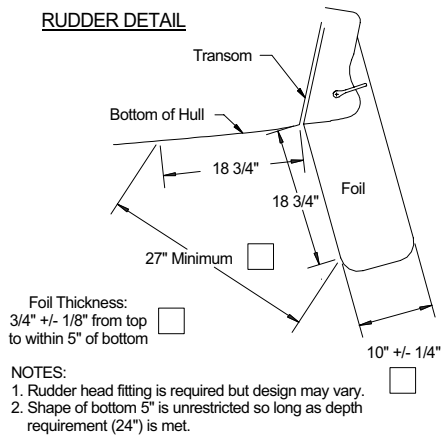

A, are
3A,

HULL NUMBER: _____
BOAT WEIGHT (DRY): _____ LBS.
REQUIRED BALLAST: _____ LBS.
RACING WEIGHT (MIN.) = 310 LBS.

Racing weight includes hull, centerboard, rudder, tiller, mast, boom, lines, rigging and other items if permanently attached and excludes sails, whisker pole, cushions, and any other items not permanently attached.

SAILS MEASURED AS FOLLOWS:

Before a sail is used for racing, it must be measured according to Article XIV of the Lido 14 Class Association By-Laws, be stamped, dated, and signed by Fleet Measurer, and must have a Lido 14 Royalty Tag attached.

Center of jib halyard block sheave or casting opening

7" +/- 1/4"

Whisker Pole:
Distance from mast,
including all fittings

Maximum

Distance of the forestay pin to the leading edge of the mast from the height of the pivot bolt

49" +/- 1/4"

Boom:
Distance to mainsail outhaul line from aft edge of mast

117 1/4" (9' 9 1/4") Maximum

Centerboard hull slot width = 1 1/8" Minimum

48" +/- 1/2"

95 1/2" +/- 1/2"

24" +/- 1/4"

NOTE:
The upper rudder depth measurement point is at the intersection of the lines representing the rudder's leading edge and the bottom of the hull. The lower point is at the intersection of the line representing the leading edge and a line perpendicular to the leading edge tangent to the rudder tip.

NOTE:
Jib fairlead track not required

Center of forestay pin to forward inside edge of jib fairlead eye - both sides

95" Minimum

Outside of fairlead to outside of opposite fairlead

64 3/4" Minimum

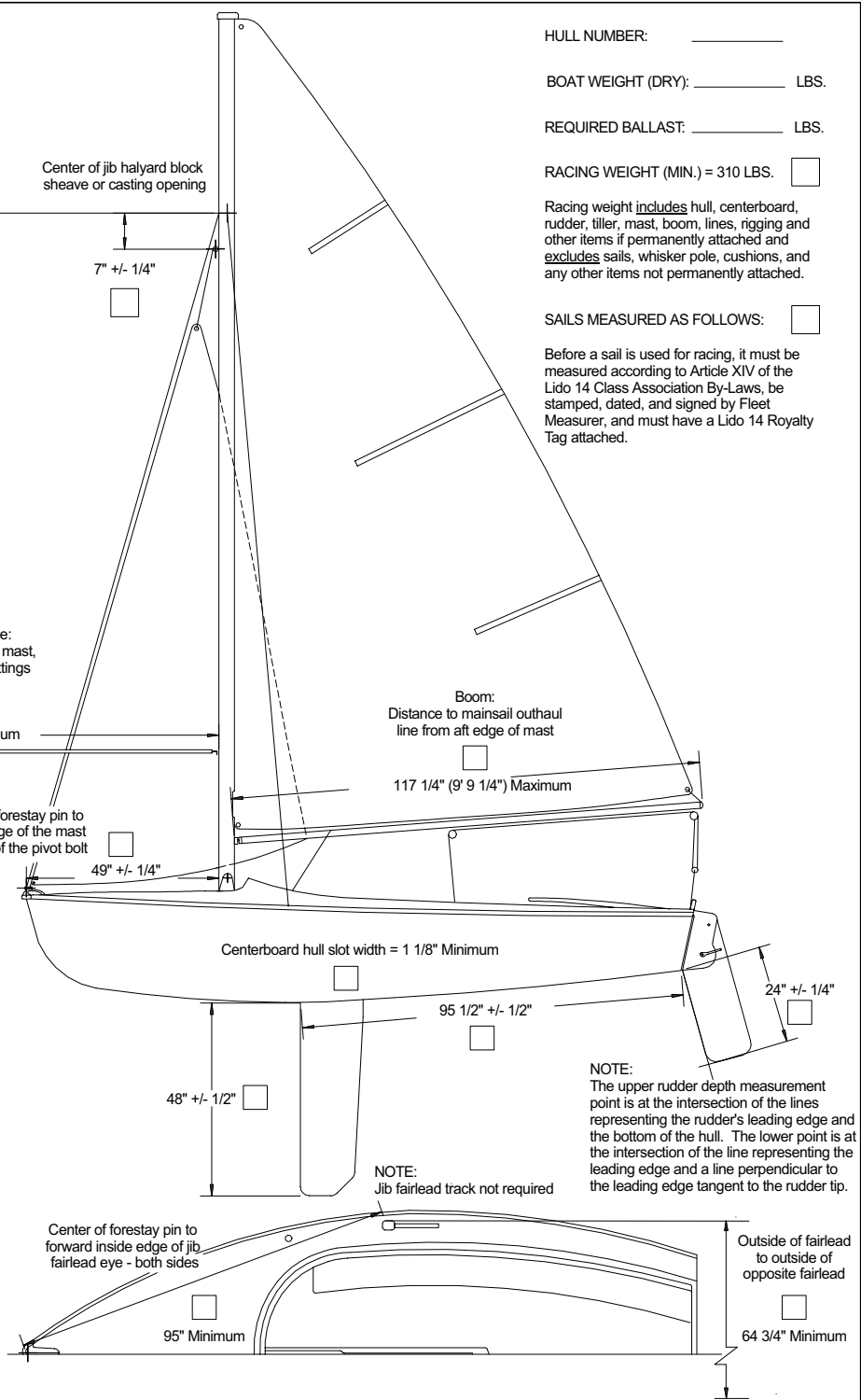



Nationals 1, 3, 6, 7, 8, 11, 14

QUANTUM
SAIL DESIGN GROUP
Where sailmaking is a performing art

George Szabo - gszabo@quantumsails.com
www.quantumsails.com/lido14

Quantum San Diego
1.619.226.2422

DoubleWave
Marine Sales, Service & Technology



Sales & Service of Lido 14s

Classic & 6000 Series Parts

Custom & Standard Rigging

Race Tuning

Custom Racing Packages

New Masts (Gold & Silver)

Mast Rebuilds

Boom Stiffening

Covers

Trailers & Dollies

Sails

Specialty Lido 14 Items

www.doublewave.com

(949) 515-0597

(949) 466-0888 (cell)

Longest Journey Trophy

Longest Distance from Home to the Class Championships

2002	Roger & Anne Hinton
2001	Allan Stults & Patty Boynton
2000	Joe Daubenberger/Julie Ann Hodgson
1999	Kent Foster
1998	Steve Orsini
1997	Joe D'Amico
1996	Kent Foster
1995	Greg Cotton
1994	Greg Cotton
1993	Greg Cotton
1992	Greg Cotton
1991	Mike Holloway
1990	Mike Bankiewicz
1989	Duncan Brown
1988	Greg Cotton
1987	Dave Carroll
1986	Kent Foster
1985	Wayne Hatch
1984	Kent Foster
1983	Wayne Hatch
1982	George Koch
1981	William Denhart
1980	Wayne Hatch
1979	Wayne Hatch
1978	Bill Miller
1977	Bill Miller
1976	Todd Wilson
1975	Wayne Hatch
1974	Bob & Nancy Kline
1973	Marilyn Lawrence
1972	Kelly Snow
1971	Marilyn Lawrence
1970	Joseph Zichwic
1969	Richard Hoover

Western Regional Championships Trophy

The Western Regional Championship Perpetual was proposed by President Roger Tilton in early 1999 and was duly approved by the Governing Board. A guiding principal for this event is to balance, geographically, opposite of the Class Championships. For example, in years where the Class Championships are to the North, the Western Regional should be sited in the South, and vice versa.

The Western Regional Championship perpetual trophy was designed by (then) Class Vice President John Papadopoulos.



<u>Year</u>	<u>Skipper</u>	<u>Crew</u>	<u>Championship Venue</u>
2001	Freddie Stevens	Fred Stevens	Richardson Bay (Sausalito), CA
2000	John Papadopoulos	Stephanie Faillers	Shilshoe (Seattle), WA
1999	John Papadopoulos	Stephanie Faillers	Richardson Bay (Sausalito), CA

2002 JR. CLASS CHAMPIONSHIPS

Mission Bay, California

July 20-21, 2002

Sponsored by Lido 14 Fleet 7 (Mission Bay, CA)

- 1st Zachary Brown & Melanie Roberts
- 2nd Garrett Brown & Graham Bell
- 3rd Brian Vanderspek & Megan Magill
- 4th Ryan Karnes & Stefanie Carroll
- 5th Andrew McDade & Will Gresham



**W.D. Schock Trophy
Jr. Class Champion**

JR. CLASS CHAMPIONS

<u>Year</u>	<u>Skipper</u>	<u>Crew</u>	<u>Championship Venue</u>
2002	Zachary Brown	Melanie Roberts	Mission Bay, California
2001	Justin Law	Morgan Sabo	Newport Beach, California
2000	Freddie Stevens	Scott Andrews	Alamitos Bay, California
1999	Freddie Stevens	Jamie DeWolfe	Alamitos Bay, California
1998	Jon Bell	Mike Oliver	Mission Bay, California
1997	Erin Robertson	Candace Chick	Mission Bay, California
1996	Steven Hochart	Jonathan Boyd	Mission Bay, California
1995	Mike Williams	Piet vanOs	Mission Bay, California
1994	Steven Hochart	Bridget Shear	Mission Bay, California
1993			
1992	Aimee Graham	Ashley Kurtz	Mission Bay, California
1991	Kevin Quan	Scott Quan	Mission Bay, California
1990	- not held -		
1989	- not held -		
1988	John Jackman		Mission Bay, California
1987	Keith Ives		Alamitos Bay, California
1986	Keith Ives	Pat Deere	Alamitos Bay, California
1985	Robert L. Brown, Jr.		Mission Bay, California
1984			
1983	Paul Blank	Steve Willits	Donner Lake, California
1982	Jon Pinckney	Julie Kerrigan	Westlake, California
1981	Ron Rosenberg		Newport Beach, California
1980	Steve Rosenberg		King Harbor, California
1979	Mike Segerblom		Mission Bay, California
1978	Mike Segerblom		Alamitos Bay, California
1977	Randy Gallman		Mission Bay, California
1976	Randy Gallman	Mike McCuen	Mission Bay, California
1975	Chris Raab		Huntington Harbor, California
1974	Hal Brown II		Yale Lake, Washington
1973	Hal Brown II		Huntington Harbor, California
1972	Kurt Wiese	Vicki Call	Alamitos Bay, California
1971	Jack Bateman		Mission Bay, California
1970	Dovell Smith	Harley Hopkins	Jackson, Mississippi
1969	Kurt Wiese	David Wallace	Newport Beach, California
1968	Carol McCord	Jerry Emry	Huntington Lake, California
1967	Mark Mason		Eugene, Oregon
1966	Chris Drake	Tom Lynch	Mission Bay, California
1965	Cal Preston	Bill Scarborough	Fort Worth, Texas
1964	Mike Carpenter		King Harbor, California
1963	Bruce McClaire	Craig Anderson	Lake Merritt, California
1962	Judy Dingle		Newport Beach, California
1961	Jerry Miller		Alamitos Bay, California
1960	Tom Schock		Newport Harbor, California
1959	- unknown -		
1958	Tom Schock		Newport Harbor, California

Fleets 23 & 28 Trophy

Winner of 1st Jr. Race

2002 Zachary Brown & Melanie Roberts
2001 Bobby Lenhart & Charlie Buckingham
2000 Justin Law & Bobby Lenhart
1999 Freddie Stevens & Jamie DeWolfe
1998 Jon Bell & Mike Oliver
1997 David Levy & Becky Lenhart
1996 John Warnock
1995 Mike Williams & Piet vanOs
1994 Steven Hochart & Bridget Shear
1993
1992
1991 Kevin & Scott Quan
1990 - not held -
1989 - not held -
1988 Pat Deere
1987 Keith Ives
1986 Dana Riddick
1985 Robert L. Brown Jr.
1984
1983 Paul Blank & Steve Willits
1982 Randy Mackingu
1981 Kirk Tobler
1980 Steve Rosenberg
1979 Mike Segerblom
1978 Mike Segerblom
1977 Tod Merrill
1976 Randy Gallman
1975 Chris Raab
1974 Robert Koch
1973 Steve Salmond
1972 Kurt Wiese
1971 Jack Bateman
1970 Robert Koch
1969 Kurt Wiese
1968 Carol McCord & Jerry Emry
1967 Mark Mason
1966 Chris Drake
1965 Kathy Hubay & Ricky Boatman

Bert Thompson Trophy

Winner of 2nd Jr. Race

2002 Zachary Brown & Melanie Roberts
2001 James DeWolfe & Aly Odeski
2000 Freddie Stevens & Scott Andrews
1999 Freddie Stevens & Jamie DeWolfe
1998 Kathy Allen & John Charvat
1997 Erin Robertson & Candace Chick
1996 John Warnock
1995 Justin Jackman & Jordan Varon
1994 Steven Hochart & Bridget Shear
1993
1992
1991 Kevin & Scott Quan
1990 - not held -
1989 - not held -
1988 John Jackman
1987 Jim Elms
1986 Robert L. Brown Jr.
1985 Robert L. Brown Jr.
1984
1983 Paul Blank & Steve Willits
1982 Jon Pinckney
1981 Ron Rosenberg
1980 Steve Rosenberg
1979 Mike Segerblom
1978 Mike Pinckney & Peter Newbre
1977 Randy Gallman
1976 Chris Raab
1975 Gregg Busche
1974 George E. Pedrick
1973 Steve Salmond
1972 Kurt Wiese
1971 Jack Bateman
1970 Dovell Smith & Harley Hopkins
1969 Mike Peters
1968 Vicki Lohman & Dovell Smith
1967 Paul Hunrichs
1966 Chris Drake
1965 Cal Preston & Bill Scarborough

Fleet 1 Trophy

Winner of 3rd Jr. Race

2002 Zachary Brown & Melanie Roberts
2001 Jon Bell & Bonnie Markle
2000 Freddie Stevens & Scott Andrews
1999 Freddie Stevens & Jamie DeWolfe
1998 Bobby Lenhart & Freddie Stevens
1997 David Levy & Becky Lenhart
1996 David Hochart & Steven Brown
1995 Justin Jackman & Jordan Varon
1994 Steven Hochart & Bridget Shear
1993
1992
1991 Kevin & Scott Quan
1990 - not held -
1989 - not held -
1988 John Jackman
1987 Jeff Tighe
1986 Keith Ives
1985 Dana Riddick
1984
1983 - race abandoned -
1982 Jon Pinckney
1981 Erik Mayol
1980 Bryan Peugh
1979 Mike Segerblom
1978 Steve Rosenberg
1977 Randy Gallman
1976 Brad Wheeler
1975 Hal Brown II
1974 Mark Weeger
1973 Steve Schock
1972 Ross Butcher
1971 Mark Hinshaw
1970 Robert Koch
1969 Ross Butcher
1968 Carol McCord & Jerry Emry
1967 Dave Riley
1966 Chris Drake

Fleet 7 Trophy

Winner or 4th Jr. Race

2002 Zachary Brown & Melanie Roberts
2001 Justin Law & Morgan Sabo
2000 Freddie Stevens & Scott Andrews
1999 Freddie Stevens & Jamie DeWolfe
1998 - Not Raced -
1997 Steven Brown & Tanner Marsh
1996 Steven Hochart & Jonathan Boyd
1995
1994 Steven Hochart & Bridget Shear
1993
1992 Mark Ivey
1991 Kevin & Scott Quan
1990 - not held -
1989 - not held -
1988 John Jackman
1987 Ron Cram
1986 Robert Brown Jr.
1985 Robert Brown Jr.
1984
1983 - not held -
1982 James Hendrickson
1981 Ron Rosenberg
1980 Steve Rosenberg & Ron Rosenberg
1979 Mike Segerblom
1978 Randy Gallman & Guy Raffee
1977 Susan Krebs
1976 Randy Gallman
1975 Bob Barnard
1974 David Watry
1973 Gregg Busche
1972 Hal Brown II
1971 Hal Brown II



Roy Woolsey Trophy

First Under 15 Years Old

Roy Woolsey, 1966/1967 Class President and currently active Lido 14 sailor in Lido 14 Fleet 1, donated this trophy in August of 1996 to recognize the "Top Sailor Under Fifteen."

2002	Garrett Brown
2001	- Not Awarded -
2000	Justin Law
1999	Justin Law
1998	Darin Jurasevich
1997	
1996	
1995	
1994	
1993	
1992	
1991	Tom Jenkins
1990	- not held -
1989	- not held -
1988	Billie Hardesty
1987	Jeff Tighe
1986	Jared Morford
1985	Robert L.Brown
1984	
1983	
1982	James Hendrickson
1981	Ron Rosenberg
1980	Steve Rosenberg
1979	Mike Segerblom
1978	Randy Gallman
1977	Susan Krebs
1976	Randy Gallman
1975	
1974	
1973	
1972	
1971	Hal Brown II
1970	Robert Koch
1969	Kurt Wiese
1968	Vicki Lohman
1967	Kurt Wiese

**LIDO 14 CLASS ASSOCIATION
(A California Non-Profit Association)**

~

ASSOCIATION BY-LAWS

As Last Amended August 2002

~

<u>ARTICLE</u>	<u>TITLE</u>	<u>PAGE</u>
I	OBJECT	46
II	POLICY	46
III	JURISDICTION	46
IV	FLEETS	46
V	GOVERNING BOARD	47
VI	EXECUTIVE OFFICERS AND DIRECTORS	47
VII	DISTRICTS	49
VIII	MEETINGS	50
IX	MEMBERSHIP	51
X	DUES	52
XI	MEASUREMENT AND REGISTRATION CERTIFICATES	52
XII	ELIGIBLE SLOOPS	53
XIII	DESIGN, CHARACTERISTICS, AND EQUIPMENT	53
XIV	SAILS	55
XV	RACING RULES	58
XVI	RIGGING	60
XVII	SANCTIONED EVENTS	60
XVIII	HONOR AWARDS	60
XIX	AMENDMENTS	61

~

**Lido 14 Class Association
P.O. Box 1252
Newport Beach, CA 92663**

**and on the world wide web at
www.lido14.org**

ARTICLE I - OBJECT

The object of the Lido 14 Class Association (herein "Association") shall be to promote Lido 14 Class racing under uniform rules and regulations and to maintain, rigidly and without deviation, the one-design features of the Lido 14 Class sloop.

ARTICLE II - POLICY

The policy of the Association shall be:

1. To cooperate with other yachting organizations and, in return, to insist on strict observance and compliance with the rules of the Association.
2. To keep the cost of acquisition and upkeep of Lido 14 Class sloops within modest limits without sacrificing high standards of performance and seaworthiness.
3. To promote and maintain a one-design class of Lido 14 Class sloops in which racing shall be to determine the skill of skipper and crew under uniform rules and specifications.

ARTICLE III - JURISDICTION

1. The Association has jurisdiction over all Lido 14 Class activities. Its By-Laws and rules govern all Lido 14 Class races regardless of by whom they are held, and are binding upon all members and fleets.
2. Permission must be obtained from the Association prior to eliminating or deviating from any requirement of these By-Laws in racing a Lido 14 Class sloop.
3. All events involving racing within the territorial waters of a fleet shall be sanctioned by that fleet through its elected officers.
4. All disputes between fleets, or a fleet and other yachting organizations, regarding the interpretation of this document shall be resolved by the Governing Board of the Association, and its decision shall be final.
5. The Association shall not be liable for any debts contracted by its officers, fleet officers, or members other than expenditures as authorized by the budget or upon written order of the President and Treasurer.
6. The Association reserves the right to declare ineligible any yacht which does not conform to the spirit as well as the letter of these rules, and the specifications and drawings of the Lido 14.

ARTICLE IV - FLEETS

1. The fleet is a territorial unit open to all eligible persons within its area. It elects its own officers, which must include a fleet secretary. The fleet is self-governing in all local matters not conflicting with the Association By-Laws and rules and has the authority to accept or reject applications for fleet membership.
2. The fleet may be divided into Senior and Junior Divisions. Each division shall elect its officers and be subject to its own rules, providing they do not conflict with these By-Laws.
3. A new fleet may be granted a charter upon application to the Governing Board by three (3) or more owners who must be members of the Association not within the territory of any organized fleet.
4. Fleet charters may be granted or suspended by the Governing Board but revoked only at an Annual Meeting. Reasons for suspension are:
 - (a) Failure to maintain, in good standing, a minimum membership and quota of Lido 14

Class sloops.

- (b) Failure to file an annual report of fleet members and dues with the Association thirty (30) days prior to the Annual Meeting or as otherwise ordered by the Governing Board. Suspension of new fleets which fail to comply with a demand from the Association is mandatory.**
- (c) Failure to comply with these By-Laws, knowingly or otherwise.**
- 5. Suspended fleets, members, and ineligible sloops shall be posted by publication, and shall be barred from all Lido 14 Class races and activities. Furthermore,**
 - (a) Suspension of a fleet suspends its members**
 - (b) Fleets, members, and sloops cannot be reinstated until Association requirements have been fulfilled**
 - (c) Fleets suspended only for nonpayment of dues shall be reinstated upon payment of unpaid dues.**
- 6. Each fleet is required to file an Annual Report with the Association during June of each year to renew its rights and privileges granted under its Association charter.**
- 7. Each fleet shall hold an Annual Meeting no later than June of each year to elect fleet officers; the results of such elections shall be filed with the Association no later than two (2) weeks after said elections.**
- 8. The amount and time of payment of fleet dues shall be fixed in fleet By-Laws.**
- 9. No member may be suspended from a fleet except by majority vote of his/her fleet.**

ARTICLE V - GOVERNING BOARD

- 1. The Board of Directors of this corporation shall be known as the Governing Board and shall consist of all executive officers, the immediate past president, the district secretaries, and the other directors specified in Article VI and shall serve for a term as specified therein.**
- 2. For purposes of doing business, a quorum shall consist of five members of the Board excluding the district secretaries. A simple majority shall decide all issues except as provided in 4. below.**
- 3. The Governing Board shall conduct all business, determine policy of the Association, and shall serve as the last court of appeals in disputes involving these By-Laws.**
- 4. The Governing Board has the authority to enforce its decision by suspension of entire fleets or individual members. The Board shall sanction or ban races, grant or revoke fleet charters, and suspend members guilty of gross violation of rules or unsportsmanlike conduct. Its rulings shall be binding and final. A three-quarters (3/4) majority vote shall decide all issues included in this section.**

ARTICLE VI - EXECUTIVE OFFICERS AND DIRECTORS

- 1. The executive officers and directors of the Association and their respective duties shall be as follows:**
 - (a) President — The President is the Chief Executive. The President shall:**
 - (1) Preside at meetings, serve as Chairman of the Governing Board, rule on procedure and jurisdiction, summarize decisions, appoint special committees and authorize payment of all bills with approval of the Governing Board.**
 - (2) Appoint a Protest Committee to hear Class Rules protests submitted to the Association**
 - (b) Vice President — The Vice President shall:**
 - (1) Officiate in the absence of the President**
 - (2) Be in charge of the Class Championship Regatta.**

- (3) **Initiate bidding and select the winning bids for the Class Championship Regatta and any Association sanctioned championship regatta above the District level. For the purpose of simplification, we will refer to these events as Association Championships.**
- (4) **The Vice President shall provide guidance to winning bidders on the conduct of Association Championships.**
- (5) **Maintain an archive of all published Notices of Race, Entry Forms, Measurement Forms, Sailing Instructions, competitor lists, trophy winners, perpetual trophy whereabouts as they pertain to Association Championships.**
- (6) **Oversee the engraving and maintenance of Perpetual Trophies associated with Association Championships.**
- (7) **Ensure that a Measurement Committee is established for each Association Championship.**
- (8) **Serve as the liaison between the Measurement Committee, the event organizers, and any other entity that may be involved with the findings of the Measurement Committee. The Vice President shall have no authority over actual measurement procedures or findings.**
- (c) **Secretary — The Secretary shall**
 - (1) **Handle all correspondence**
 - (2) **Record the minutes of meetings**
 - (3) **Maintain an accurate and current record of members, fleets, and fleet officers.**
 - (4) **Notify the membership of special events, decisions affecting policy, banned races, suspended members and/or fleets, and ineligible Lido 14 Class sloops.**
- (d) **Treasurer — The Treasurer shall:**
 - (1) **Maintain financial records and securities of the Association.**
 - (2) **Deposit funds and disburse funds only on order of the President, with the approval of the Governing Board.**
- (e) **Chief Measurer — The Chief Measurer shall:**
 - (1) **Be in charge of all certified measurers on the Measurement Committee assembled for the Class Championship Regatta.**
 - (2) **Grant or reject all measurement certificates, maintain a record of all granted measurement certificates, issue duplicates, and answer all questions from fleet measurers regarding measurement rules.**
 - (3) **Interpret the rules and regulations on matters not specifically covered in the official plans and specifications. Such rulings shall be subject to approval of the Governing Board. The Chief Measurer shall not approve changes in construction specifications, sail plan, or rigging. Rulings of the Chief Measurer approved by the Board shall be included in the annual report of the Chief Measurer.**
 - (4) **Compile a report prior to each Governing Board meeting detailing the approved and disapproved changes that he/she has ruled on since his/her last report. Each ruling made by the Chief Measurer shall include the date of the ruling, details of the proposed change (i.e. drawings, photographs, descriptions), the Chief measurers arguments for and against the proposed change, and references to by-laws and past approved and disallowed changes that apply.**
 - (5) **Be in charge of all Fleet measurers. Related duties shall include publication of approved rulings to each Fleet Measurer, securing and distributing measurement equipment for fleets, overseeing the design and development of measurement equipment, writing and/or updating a measurement handbook containing recommended measurement practices, comments regarding the historical variations of Lido 14s as they pertain to measurement.**

(5) The term of office for all officers of the section shall be one (1) year.

3. District officers:

- (a) **District Secretary** — The District Secretary shall be a member of the Governing Board and shall have general supervision over all Association activities in the district. He or she shall coordinate policy and decisions of the Governing Board with each fleet in the district.
- (b) **Alternate District Secretary** — The Alternate District Secretary shall officiate during any prolonged absence of the District Secretary. Should the office of District Secretary become vacated, the Alternate District Secretary shall become district secretary for the remainder of the un-expired term.
- (c) The District Secretary shall be elected by the mail vote of the fleets in each district. The election must be held in advance of the annual meeting of the Association and the District Secretary elected shall serve during the ensuing year. The person receiving the second greatest number of votes shall be the Alternate District Secretary immediately after the election.

ARTICLE VIII - MEETINGS

- 1. The annual meeting of the Association should be held in the period and vicinity of the Class Championship Regatta. Special meetings by order of the Governing Board or upon demand in writing by twenty-five percent (25%) of the fleets must be held. Time and place of all meetings must be fixed by the Governing Board.
- 2. Meeting notices shall be sent to the last recorded secretary of each fleet in time to permit action by delegate or proxy. If it is a special meeting, the purpose thereof must be plainly stated in such a form as to permit voting by mail. No business other than that stated can be transacted.
- 3. Representatives of one-half (1/2) of the fleets in good standing shall constitute a quorum at meetings. If a quorum exists at roll call, it exists throughout the session of the meeting.
- 4. The membership of each fleet shall select and instruct a delegate. If unable to send a delegate, the fleet shall sign and deliver to the Association Secretary, a duly authorized proxy to present the fleet's views and cast its votes at all meetings.
- 5. Any number of alternates or proxies may be named but the first, in the order presented, shall be the only one entitled to cast the fleet's votes. Only those alternates or proxies properly certified in writing by the proper fleet officers will be recognized.
- 6. Each fleet shall be entitled to cast one (1) vote for each Lido 14 Class sloop enrolled in that fleet, which has been properly recorded with the Association by an active member in good standing.
- 7. No fleet is entitled to more than thirty-three and one third percent (33 1/3%) of the total number of votes cast. No more than one (1) vote shall be allowed for any one (1) member no matter how many Lido 14 Class sloops he or she may own.
- 8. For the purpose of determining each fleet's percentage of the total vote cast, the Governing Board shall close the Membership books thirty (30) days before the annual meeting, or as ordered by the Governing Board. The membership books shall reflect those members in good standing for the membership year closing at the Annual Meeting.
- 9. Members may be heard, but only accredited delegates, proxies, alternates, and unattached members may vote on motions. All fleet delegates or unattached members must vote on each motion unless excused by the Chairman of the annual meeting. A majority of votes cast shall decide all questions not otherwise stipulated.
- 10. Chairman of the annual meeting shall cast the deciding vote in case of tie and may fix a time limit on speakers and debate on motions.

11. The order of business at the annual meeting shall be:

- (a) Call to order**
- (b) Roll call of fleets**
- (c) Minutes of last meeting**
- (d) Report of executive officers**
- (e) Report of charters granted and revoked**
- (f) Ratification of Governing Board rulings**
- (g) Unfinished business**
- (h) New business**
- (i) Election of officers**
- (j) Adjournment**

ARTICLE IX - MEMBERSHIP

- 1. Applications for membership in the Association shall be made through the fleet in whose jurisdiction or territory the applicant normally sails, and if no fleet has jurisdiction over such territory, then such application shall be given directly to the Association. A member of this Association not in a fleet shall be known as an unattached member.**
- 2. A member, while in good standing in the Association, shall be eligible to race in any sanctioned race outside of his territorial fleet. However, he or she shall conform to the local fleet rules and regulations where he or she is racing. The member shall hold their "Official Certificate of Measurement" to demonstrate ownership, official measurement and membership in the Association when racing outside his or her fleet or its territorial waters.**
- 3. Any member may only be expelled from the Association by three-quarters (3/4) vote at an annual meeting.**
- 4. New applicants for membership shall not be considered eligible to race in the Lido 14 Class until all measurement certificates, registration forms, and paid-up dues are recorded by the fleet to which he or she belongs, if one exists, and the Association.**
- 5. Members who are delinquent in either their fleet or Association dues shall be ineligible and disqualified from racing until such dues are paid in full. Members who race when delinquent in their dues may be suspended.**
- 6. When a member ceases to be a Lido 14 Class sloop owner, his membership shall be retained, along with his racing eligibility, until the end of the calendar period when his dues are payable again.**
- 7. A member cannot belong to more than one (1) fleet at one time nor can a Lido 14 Class sloop be registered in more than one (1) fleet at one time.**
- 8. Senior division membership classification:**
 - (a) Senior member — A sole owner of a properly certified and registered Lido 14 Class sloop who is nineteen (19) years of age as of December 31, or over, and is a member in good standing.**
 - (b) Senior syndicate member — A part owner of a properly certified and registered Lido 14 Class sloop who is nineteen (19) years of age as of December 31, or over, and is a member in good standing. Each syndicate member must own at least an individual one-third (1/3) interest in a Lido 14 Class sloop. Only one (1) syndicate member per boat may vote or have the privilege of holding office.**
 - (c) Spouse member — The spouse of a senior member or a senior syndicate member.**
 - (d) Senior dependent member — The dependent of a senior member or a senior syndicate member who is 18 years of age, or over.**
- 9. Junior division membership classifications:**
 - (a) Junior member — A sole owner of a properly certified and registered Lido 14 Class**

sloop who is under nineteen (19) years of age as of December 31 and is a member in good standing.

- (b) **Junior syndicate member** — A part owner of a properly certified and registered Lido 14 Class sloop who is under nineteen (19) years of age as of December 31 and is a member in good standing. Each syndicate member must own at least an individual one-third (1/3) interest in a Lido 14 Class sloop.
 - (c) **Junior dependent member** — The dependent of a senior or a senior syndicate member who is under nineteen (19) years of age as of December 31.
10. **"Guest"**: A skipper who is not an Association member may be a guest of one (1) sponsoring Lido 14 fleet for three (3) Regattas or series per calendar year.
- (a) The guest must obtain the approval from the sponsoring fleet (typically from the fleet Captain) prior to racing in the regatta.
 - (b) Guest skipper names shall be submitted to the Association Secretary within a month after the regatta.
 - (c) The boat used by a guest must conform to measurements of the Association.
 - (d) A guest may not compete in a District or Class Championship.
11. **"Associate"**: Any person wishing to associate with Lido 14 sailors, and to be listed in the directory, and to receive the Bow Wave and other published literature. This classification has no voting or racing rights.

ARTICLE X - DUES

1. Both Association and fleet dues must be paid before any member can be considered in good standing. Paying of dues on or before the required date, shall be the sole responsibility of each individual member.
2. The annual dues of the Association shall be:

Class of Membership	Dues
Senior member	\$28.00 per person
Senior syndicate member	\$28.00 per person
Senior dependent member	\$5.00 per person
Spouse member	No Dues
Junior member	\$5.00 per person
Junior syndicate member	\$5.00 per person
Junior dependent member	No Dues
Associate	\$10 per person
Guest	No Dues
3. Fleet dues shall be determined by each fleet and retained for use by that fleet.
4. Association dues shall be collected by each fleet secretary and forwarded to the Association Secretary thirty (30) days before the annual meeting or as ordered by the Governing Board. Members in good standing will be issued a current membership card and a decal to be applied to the upper starboard corner of the transom on the outside thereof.
5. The Governing Board may authorize the proration of dues to periods less than one year.

ARTICLE XI - MEASUREMENT AND REGISTRATION CERTIFICATES

1. The Association's "Official Certificate of Measurement and Registration," as issued by the Chief Measurer, shall be binding upon all organizations conducting races for the Lido 14 Class.
2. A yacht holding a valid "Official Certificate of Measurement and Registration", signed by the fleet measurer, or his proxies as witnessing the measurements, and the Chief Measurer as

accepting those measurements, shall not be subject to measurement or protest on measurement unless reasonable ground can be shown to give evidence of subsequent alterations. However, a Lido 14 Class sloop is always subject to re-measurement by order of the fleet officers, the Governing Board officers, class race committee and/or the Measurement Committee at the Class Championship Regatta.

3. Fleet measurers shall be restricted in authority to the actual measurement and recording of measurements on the "Official Certificate of Measurement and Registration." Rulings on controversial changes, or changes that affect sailing characteristics, must be referred to the Chief Measurer for evaluation and presentation to the Governing Board.
4. Fleet measurers shall not measure their own boats except under supervision of a disinterested fleet or Association officer.

ARTICLE XII - ELIGIBLE SLOOPS

1. A sloop is eligible and considered in the Lido 14 Class only if it:
 - (a) Conforms to measurement specifications and rules as certified by an Association "Official Certificate of Measurement and Registration" form that has been signed by the fleet measurer, or his proxy, and the Chief Measurer.
 - (b) Is owned by a paid-up member of the Association.
 - (c) Has current decal located, as specified in Article X, Section 4, indicating Class dues are paid.
2. It shall be the responsibility of all members of the Association to insure that entrants in Lido 14 Class events are eligible to race.
3. Ineligible yachts and skippers shall be protested, either by notifying the race committee prior to the start of a race, or by filing a class rules protest at the conclusion of a race, races, or regatta.
4. Protest
 - (a) A Yacht suspected of ineligibility may be protested for violation of class rules at any time.
 - (b) Class rules protests filed during a regatta shall conform to the filing procedures of said regatta
 - (c) Class rules protests may be filed, at any time, with the Class Secretary. Such protest shall be processed in their order of filing only after the assembly of a Protest Committee
5. No special dispensation of eligibility will be granted by an individual or organization to a yacht sailing in the Lido 14 Class without prior written approval of fleet officers or the class officers.
6. Yachts found ineligible as a result of a Class Rules protest shall, at a minimum, be scored with a disqualification (DSQ) for all races said yacht was protested for.

ARTICLE XIII - DESIGN, CHARACTERISTICS, AND EQUIPMENT

1. It shall be illegal to produce a mold of the Lido 14 Class sloop without specific permission and approval of the Governing Board and the W.D. Schock Corporation, which holds the Copyright #1-lu-10556.
2. Changes of the Lido 14 Class sloop, without prior approval of the Association, are illegal, and such yachts incorporating unapproved changes shall be declared ineligible for racing and membership in the Association.
3. Numbers, corresponding with the racing number on the main sail, shall be molded into the hull. These numbers shall be issued only by the W.D. Schock Corporation.

4. All measurements, equipment, and characteristics of the Lido 14 Class sloop shall comply with details listed and described on the "Official Certificate of Measurement and Registration," and as listed herein. All other changes made solely for convenience and ease of operation must be approved by the fleet measurer through the Chief Measurer and the Governing Board.
5. The rudder and centerboard may be molded and/or constructed of any material which is reasonably homogeneous. The surface finish or reinforcing materials must be of a reasonably constant thickness over the entire board area. The tiller may be constructed of any material.
 - (a) All centerboards and rudders must be measured and must meet the specifications below, whatever their finish.
 - (b) Rudder Specifications:
 - (1) Width — 10 inches plus or minus 1/4 inch.
 - (2) Length — 24 inches plus or minus 1/4 inch from bottom of boat.
 - (3) Thickness — 3/4 inch plus or minus 1/8 inch continuous from top to within 5 inches of bottom. The thickness measurement shall be taken at the thickest point between the leading and trailing edges.
 - (4) The angle of the rudder when fully lowered shall be limited by a minimum measurement of 27 inches between a point on the hull bottom 18 3/4 inches forward of an extension of the leading edge of the rudder and a point on the leading edge of the rudder 18 3/4 inches below an extension of the bottom line of the hull.
 - (c) Centerboard Specifications:
 - (1) Width below the hull — 12 7/8 inches plus or minus 1/4 inch to 6 inches below the pivot point with a constant taper to 11 7/8 inches plus or minus 1/4 inch at 42 inches below the pivot point.
 - (2) Length — 50 inches plus or minus 1/4 inch from the pivot point to the bottom and 60 inches maximum overall.
 - (3) Thickness — 7/8 inch plus or minus 1/8 inch continuous from top to within 8 inches of bottom. The thickness measurement shall be taken at the thickest point between the leading and trailing edges.
 - (4) Weight shall be from 11 pounds to 18 pounds.
 - (5) Fore and aft location of the centerboard:
 - a. For the hull numbers of 3450 and greater the centerboard shall be located fore and aft in the hull such that in the fully extended position the distance, measured along the hull on the centerline from the centerboard's leading edge to the transom/bottom intersection is 95 1/2 inches plus or minus 1/2 inch
 - b. For hull numbers of 3449 and smaller the pivot point is 1 7/8 inches plus or minus 1/4 inch from the centerboard's leading edge. Boats may be modified to comply (no modification may be made except to comply with paragraph (a) above). Any such modification shall be verified and recorded by the fleet measurer on the measurement certificate.
 - (6) The allowable limit of centerboard jibing is satisfied if the leading edge of the centerboard that lies within the centerboard well or slot does not move more than 1/4 inch more than the trailing edge of the board.
6. Hiking straps may be installed without restriction except that when loaded they shall not extend above or beyond the gunwale and that they, and no part thereof, shall be attached to the flotation tanks. [Ed. See Approved Change 20.]
7. The minimum weight shall be three hundred and ten (310) pounds and shall include the hull, centerboard, rudder, tiller, mast, boom and rigging but not include sails, whisker pole, cush-

ions, and other equipment.

- (a) Ballast required to meet the minimum weight need not be affixed to the boat, but shall be in addition to ballast required to meet the minimum crew and skipper weight and shall not be shifted during the race and shall not consist of boat accessories.
 - (b) Measurers will place upon the certificates for boats measured a statement of the weight of ballast required.
 - (c) Ballast required for boat weight may be protested in a race upon the same conditions as ballast for crew weight may be protested.
8. July 2001: Rescinded (concerning wetted surface of the boat)
 9. Self bailing equipment is no longer allowed as optional equipment. Self bailing equipment installations that meet all of the following conditions are allowed:
 - (a) Installations must comply with the 2001-2002 class rules concerning self bailing equipment [Ed. Refer to Article XIII.9, Approved Change #3, and Approved Change #46]
 - (b) Installations must be documented on the boat's Certificate of Measurement and Registration
 10. Unique or modified hardware for the Lido 14 Class Sloop must meet the following requirements:
 - (a) Be as safe and durable as that supplied by W.D. Schock Corporation
 - (b) Be easily and inexpensively duplicated for use by other boat owners
 - (c) Not significantly lighten, or increase the speed of, the boat
 - (d) Meet all written rules and By-Laws of the Association
 - (e) Be subject to ruling by the Chief Measurer and Governing Board
 11. The whisker pole may be of any material but may not be longer than six (6) feet including the mast fitting.

ARTICLE XIV - SAILS

INSIGNIA

1. The mainsail is to be marked with the approved Lido 14 Class Insignia: a script "L" and the block number "14". The identifying letters and figures are to be blue on white sails and may be white, dark blue or black on blue sails and conform to the design shown on the sail plan. The height of the "L" shall be a minimum of seventeen (17) inches and a maximum of eighteen (18) inches. The racing numbers shall be ten (10) inches in height.

RULES FOR ALL SAILS

2. Sails shall be made of woven material only, either natural or synthetic, such as cotton or Dacron. Materials incorporating plastic film such as Mylar or aromatic polyamide fibers (Kevlar) are prohibited as sail material, either in the body of the sail or as reinforcement, tabling or bolt ropes. This prohibition does not preclude the installation of windows as allowed below.
3. All sails shall be stamped on the tack of the sail by the fleet measurer with a miniature of the "L-14" insignia. The Chief Measurer shall issue these stamps to all certified fleet measurers.
 - (a) The fleet measurer shall include, within the insignia, his initials and the date the sail was measured.
 - (b) Sails not stamped with the official "L-14" stamp, dated and signed by the fleet measurer, shall be considered illegal and shall disqualify the boat from racing eligibility.
 - (c) New sails shall be measured and stamped by the fleet measurer prior to use.
4. During a member's first Lido sailing season, he or she may use only two (2) mains and two (2) jibs.

- (a) The use of additional sails shall be limited to one (1) main and one (1) jib for any subsequent calendar years, for each member. Syndicate members owning one boat are considered as one member for the purpose of this rule.
 - (b) In the event of an emergency or special race instructions, exceptions are allowed on the approval of a local fleet officer or a member of the Governing Board.
 - (c) Spouse members and dependent members are limited to the use of the sails which are allowed for the member whose boat they are sailing.
5. Borrowed sails
- (a) Shall not be used in the Class Championship Regatta except in emergencies when allowed at the discretion of the Chief Measurer.
 - (b) Restrictions limiting the use of borrowed sails shall be waived for all junior and women's regattas, including the Junior Class Championships
6. There shall be three (3) battens only and they shall be spaced equally in the leech of the mainsail and be not in excess of twenty-four (24) inches, thirty-six (36) inches and thirty (30) inches in length respectively from top batten to bottom batten.
- (a) Except for said three (3) battens and the approved headboard, there shall be no other battens or means of stiffening the leech or foot of either sail.
 - (b) Batten pockets shall have not more than two (2) extra thicknesses of cloth.
7. Any means of artificially changing the shape or length of the foot, leech or luff of either jib or mainsail is prohibited.
8. The dimensions for sails as given are for maximum measurements.
- (a) Sails over dimensions on any side are not allowable.
 - (b) Sails are subject to re-measurement and cancellation of approval at any time.
 - (c) Disregard roaches, use straight line measurements, taken to the center of the grommets located just inside the corner of the sails.
 - (d) A light pull of about five (5) pounds shall be applied to the corner which is opposite the side being measured.
 - (e) The luff of the jib shall be subjected to a direct-line pull of thirty (30) pounds while it is being measured; leeches shall be subjected to a direct-line pull of five (5) pounds.
9. A window of clear material may be placed anywhere in the bottom four (4) feet of the jib and main – including the entire area of the bottom four (4) feet.
10. Foot Reference Line – An imaginary straight line is to be drawn through the center of the tack grommet and the center of the clew grommet from the luff and leech edges of the sail. This line is to be called the "foot reference line".
- (a) The distance of the "foot reference line" from the center of the grommet to the edge of the sail (excluding bolt rope on main) will represent the measurement from the respective grommets to the luff and leech of the sail.
 - (b) A line perpendicular to the "foot reference line" will represent the measurement from the grommets to the foot of the sail.
 - (c) The "foot reference line" is also to be used for measuring the round of the foot.
11. In measuring the round of the foot, its shape will be that of a "fair curve." This means that when a line is drawn tangent to the curve, it shall touch this "fair curve" at no more than one place.
12. All sails must have a royalty tag affixed. These may be purchased from the Treasurer at a price to be determined by the Governing Board; the revenue there from shall be accounted for in the General Fund.
13. Spinnakers are not permitted.

MAIN SAIL

14. The headboard of the mainsail, measured perpendicular to the luff rope, shall not exceed four (4) inches.
15. The tack of the mainsail shall have only one (1) grommet; the tack grommet shall be large enough to accept the hook on the top of the original Lido 14 gooseneck design.
16. Dimensions of the main shall not exceed the following:
 - Luff — top of the black band to the top of the mast using a 3/4 inch shackle.
 - Leech — 18 feet 1 1/4 inches maximum
 - Foot — 9 3/4 inches maximum
 - Quarter-Point Girth— 3 feet 7 inches maximum excluding bolt rope
 - Midpoint Girth— 6 feet 1 1/2 inches maximum excluding bolt rope
 - Three-Quarters-Point Girth— 8 feet 1 inch maximum excluding bolt rope
 - Round of foot — 5 inches maximum from foot reference line
 - Head grommet — 1 1/2 inches maximum from luff of sail (excluding bolt rope) and 7/8 inch maximum from top of sail to center of grommet
 - Tack grommet — 1 3/8 inches maximum from luff of sail (excluding bolt rope) and 7/8 inches maximum from foot of sail to center of grommet
 - Clew grommet — 7/8 inch maximum from both leech and foot of sail to center of grommet
17. Quarter-Point Girth Measurement Procedure
 - (a) Determine the luff Quarter-Point by folding the center of the head grommet to the midpoint of the luff and marking the luff fold point.
 - (b) Determine the leech Quarter-Point by folding the center of the head grommet to the midpoint on the leech and marking the leech fold point.
 - (c) Spread the sail out flat, smoothing out the wrinkles and measure between the marked points, excluding the bolt rope. Only the tension necessary to remove wrinkles need be applied.
18. Midpoint Girth Measurement Procedure
 - (a) Determine the Midpoint of the luff by folding the sail until the center of the grommet in the headboard coincides with the center of the grommet at the tack.
 - (b) Determine the Midpoint of the leech using the headboard grommet and the grommet at the clew.
 - (c) Spread the sail out flat, smoothing out the wrinkles and measure between the points, excluding the bolt rope. Only the tension necessary to remove wrinkles need be applied.
19. Three-Quarters-Point Girth Measurement Procedure
 - (a) Determine the luff Three-Quarters-Point by folding the center of the head grommet to the midpoint of the luff and marking the luff fold point.
 - (b) Determine the leech Three-Quarters-Point by folding the center of the head grommet to the midpoint on the leech and marking the leech fold point.
 - (c) Spread the sail out flat, smoothing out the wrinkles and measure between the marked points, excluding the bolt rope. Only the tension necessary to remove wrinkles need be applied.
20. The leech of the mainsail shall be inside a straight line between outside edge of the headboard and the Quarter-Point Girth measurement point.

JIB SAIL

21. Sheets for the jib sail must be rigged and controlled outside the mast shrouds.
22. Dimensions of the jib sail shall not exceed the following:
 - Luff — 12 feet 1/4 inch maximum using a 30 pound pull
 - Leech — 10 feet 7 1/4 inches maximum
 - Foot — 6 feet 3 1/4 inches maximum
 - Head Girth — 11 inches maximum
 - Midpoint Girth— 3 feet 3 1/4 inches maximum across
 - Round of Foot — 5 inches maximum from foot reference line
 - Head grommet — 7/8 inch maximum from both luff and leech of sail to center of grommet
 - Tack grommet — 1 inch maximum from luff of sail and 7/8 inch from foot of sail to center of grommet
 - Clew grommet — 7/8 inch maximum from both leech and foot of sail to center of grommet
23. Head Girth Measurement Procedure
 - (a) Measure 17 1/4 inches along the leech from the midpoint of the head grommet
 - (b) Measure 17 1/4 inches along the luff from the midpoint of the head grommet
 - (c) Mark these points and measure the distance between them
24. Midpoint Girth Measurement Procedure
 - (a) Determine the Midpoint of the luff by folding the sail until the center of the grommet in the headboard coincides with the center of the tack grommet.
 - (b) Determine the Midpoint of the leech by folding the sail until the center of the grommet in the headboard coincides with the center of the clew grommet.
 - (c) Spread the sail out flat, smoothing out the wrinkles and measure between the points. Only the tension necessary to remove wrinkles need be applied.
25. The jib must have at least five (5) hanks; one (1) near each end of the luff and three (3) evenly spaced between them.
26. No batten or headboard is permitted in the jib.

ARTICLE XV - RACING RULES

1. Except as covered in (a) below, a Lido 14 Class sloop shall be sailed by the same skipper in each race of a series of races in which it participates. The skipper and helmsman shall be one and the same person. The skipper shall be a member of the Association.
 - (a) Except for a District or Class Championship, if the same team races a Lido 14 Class sloop in every race of a regatta or series, the individual registered as the skipper on the race entry (the "Registered Skipper") may trade places with the crew for some races provided that:
 - (1) The Registered Skipper acts as helmsman for at least half of the races
 - (2) The Registered Skipper shall be a member of the Association
 - (3) No skipper changes may be made during a race
 - (4) If either skipper is assigned to the "A" flight [Ed. See Article XV, Paragraph 11], the boat shall be entered in the "A" flight.
2. The minimum number of persons racing in a Lido 14 Class sloop shall be two (2).
3. Every race in a series of races must be completed with the same number of crew aboard as started in the first race of such series.
4. The total minimum weight of skipper, crew and ballast shall be three hundred (300) pounds except that the minimum shall be two hundred (200) pounds in the Junior Class Championships. Ballast carried to make up the weight shall not consist of boat "acces-

- sories" and shall not be shifted during the race.
5. **Aug. 2002: Rescinded (concerning the rudder position while sailing)**
 6. **The mast shall be banded with a three-quarter (3/4) inch wide black band, 16 feet 11 inches from the top of the mast, excluding the top fitting on the mast, to the top of black band on the mast.**
 7. **The luff rope, at the tack of the sail, shall not be pulled below the top of the black band.**
 8. **The tack of the main need not be attached to the gooseneck fitting; the downhaul line may be passed through the tack grommet for easy adjustment of the downhaul.**
 9. **The jib must have all hanks properly attached to forestay when racing.**
 10. **The whisker pole for the jib sail shall be attached to the mast at all times during use.**
 11. **"A" & "B" Flight Assignment**
 - (a) **In the absence of other criteria expressly stated in the race announcement or sailing instructions, a skipper in a "Major Regatta" may sail as a member of the "B" Flight unless he or she is assigned to the "A" Flight. A Major Regatta is any regatta in which there are ten (10) or more boats registered in the Flight (e.g., A or B, Gold or Silver) in which the skipper is sailing. A skipper is assigned to the "A" Flight, and shall sail as a member of the "A" Flight, if:**
 - (1) **July 2001: Rescinded (concerning fleet champions being assigned to "A" Flight).**
 - (2) **Aug. 2002: The skipper has qualified for a performance trophy by finishing in one of the first ten (10) positions of the Gold Flight of the Class Championship Regatta last sailed.**
 - (3) **The skipper has been awarded a first place in "B" Flight competition (or Silver Flight where championship scoring is utilized) in a Major Regatta.**
 - (4) **The skipper has qualified for a performance trophy in first through fifth position in "A" Flight competition in a Major Regatta.**
 - (b) **Once a skipper has been assigned to the "A" Flight, he or she shall no longer be eligible to compete as a member of the "B" Flight in a Major Regatta until after 13 months have elapsed.**
 - (c) **Nothing herein shall prevent a skipper who has not been assigned to the "A" Flight from electing to compete in the "A" Flight provided he or she shall have actively raced a Lido 14 for sixty (60) days or more as otherwise defined in these By-Laws. An election to compete with the "A" Flight in a particular Regatta shall not preclude him or her from thereafter competing in "B" Flight competition unless he or she shall be assigned to the "A" Flight as above defined.**
 12. **There shall be a Class Championship Regatta and a Junior Class Championship Regatta. There shall be two (2) winners of the Class Championship Regatta, one representing the Gold Flight and one representing the Silver Flight. Assignment to the Gold or Silver Flight shall be based upon a ranking system where the top one-half of all entrants are assigned to the Gold Flight and the remainder to the Silver Flight. The Current Class Champion, unless they decline by the close of Class Championship Regatta registration, shall be pre-assigned to the Gold Flight; all subsequent rankings shall be based upon the results of a series of preliminary races sailed at the Class Championship Regatta. In addition there shall be a Junior Class Champion. The Class Championship Regatta shall be open to all members irrespective of age.**

ARTICLE XVI - RIGGING

1. The main sheet shall be rigged as shown on the "Official Certificate of Measurement and Registration."
2. July 2001: Rescinded (concerning rigging of main sail clew outhaul).
3. In rigging the centerboard to provide ease of control from either side, a single block may be attached to the centerboard arm, and two (2) single blocks or one (1) double block may be attached to the hull boom vang fitting. A jamb cleat may be installed on each side of the centerboard trunk. A line passing through the jamb cleat to the first block at the boom vang fitting, back through the block on the centerboard arm, down through the second boom vang fitting block and back to the other jamb cleat will provide a means of adjusting the board with ease from either side of the centerboard trunk.
4. A mast preventer may be rigged between mast and shrouds at a point six (6) inches plus or minus one half (1/2) inch below the spreaders. The preventer will be constructed of two (2) wire legs attached to the forward edge of the mast. The length of the legs shall be such that there is no distortion of the shrouds when the mast is perpendicular.

ARTICLE XVII - SANCTIONED EVENTS

1. All series or races for Lido 14 Class Championships, territorially greater than one fleet, or events for perpetual, semi-perpetual or open trophies must be sanctioned in writing to the sponsoring organization by the fleet in whose waters the event is held.
2. The method of determining the qualifications of the right to enter the Class Championship Regatta shall be set up by the Governing Board. Fleet members representing a fleet quota must be authorized as eligible to compete by that fleet.
3. Aug. 2002: Only members of the Association, who have actively raced in the Lido14 Class for a minimum of sixty (60) days prior to the Class Championship Regatta, shall be considered eligible to race in the Class Championship Regatta. Any person who has not reached their 19th birthday by December 31 of that calendar year is eligible to race in the Junior Class Championship Regatta.
4. The Class Championship Regatta shall be held in the second week of August or such other date as may be fixed by the Governing Board, provided it shall not be held in the same district for more than two (2) consecutive years and shall not be held in the same fleet location as held in the previous year unless no other fleet is willing or able to have it.
5. Aug. 2002: [Ed. Redundant to Article XV.12]
6. The W.D. Schock Trophys awarded to the Class Champion and Junior Class Champion shall be retained for the ensuing year at the winners' yacht clubs. They shall be returned to the Association at least thirty (30) days prior to the first race of the Class Championship Regatta.
7. Entrants in the Class Championship Regatta shall have an "okay to race" from the Chief Measurer, or his proxy, and the Class Championship Race Committee, prior to competition.
8. Crew in a Junior division Championship Regatta shall be under nineteen (19) years of age as of December 31.

ARTICLE XVIII - HONOR AWARDS

1. Present and past winners of any of the following Lido 14 sailing honors shall display on their sails the insignia showing the highest honor they have ever won along with a small year numeral showing the most recent year that particular honor was won. Honors and their insignia, rank in the following order:

- (a) **Class Champion (Class Championship Regatta Gold Flight First Place): Gold L**
 - (b) **Class Championship Regatta Gold Flight Second Place: Two (2) gold chevrons**
 - (c) **Class Championship Regatta Gold Flight Third Place: One (1) gold chevron**
 - (d) **District Champion: Silver L**
 - (e) **Fleet Champion: Red L**
 - (f) **Junior Class Championship Regatta First Place: Green L**
 - (g) **Junior District or Junior Fleet Champion: Black L**
2. **Honor awards are made to the skipper and not the boat. It is suggested that the trophy committee for the championship in question provide in advance the appropriate honor insignia, including the year numeral and make physical presentation of the insignia to the skipper at the same time the trophy for the event is awarded.**
- (a) **A skipper shall carry his highest honor insignia on the sail of any Lido 14 Class sloop he or she may own while a member of the Association. This includes a returned skipper who may have left the Association for a period of time.**
 - (b) **Junior honor insignia shall be the only exceptions to paragraph 2(a). A green L or black L shall be removed within two (2) years of the Junior's becoming a Senior.**
 - (c) **A skipper selling his boat or sails has the responsibility before transferring ownership of removing from the sails any honor insignia to which the new owner is not entitled.**
 - (d) **In a syndicate owned or family boat, if the part-owner carrying honors leaves the Association, the remaining owners shall remove the honor insignia within a reasonable time.**
3. **Specifications for honor insignias are as follows:**
- (a) **The expressions "Gold L," "Silver L," etc. include both the script "L" and the block number "14." In size, shape and position, they are the same as the standard blue sail insignia described in Article XIV - Sails.**
 - (b) **Chevrons shall be vertically stacked, parallel to the leech, apex upward, approximately three (3) inches apart, below the numeral. Width of the chevron is six (6) inches, thickness of the arm is 1 1/4 inches, and angle at which the two (2) arms meet is 120 degrees.**
 - (c) **The "small year numeral" shall be a two-digit number signifying the year in question (i.e., 67 for 1967). The year numeral is 4 inches high, is of the same color as the honor award, and is centered approximately 3 inches below the honor award.**

ARTICLE XIX - AMENDMENTS

- 1. **The By-Laws may never be suspended but may be amended following the procedures set forth in this Article.**
- 2. **Amendments may be proposed in either of two (2) ways: they may be proposed by the Governing Board or they may be initiated by a majority vote of the delegates present at the Annual Meeting.**
 - (a) **Any amendment proposed by the Governing Board of which notice is duly given in accordance with paragraph 3, below, and which is enacted in accordance with paragraph 4, below, shall be effective immediately upon enactment or at such later date as is specified in the amendment.**
 - (b) **Any amendment which is initiated by a majority vote of the delegates present at the Annual Meeting must be voted on after notice has been duly given in accordance with paragraph 3, below. Following such notice, when any such amendment is enacted in accordance with paragraph 4, below, it shall be effective immediately upon enactment or at such later date as is specified in the amendment.**

3. The full text of any amendment proposed in either of the two (2) ways set forth in paragraph 2, above, shall be included in the notice of the Annual Meeting or Special Meeting at which it is to be voted on, which notice shall be mailed to the general membership not later than thirty (30) days before the date of the meeting.
4. A proposed amendment of which notice has been duly given in accordance with paragraph 3, above, shall be enacted only if it receives a fifty-one percent (51%) or more majority vote of all paid members in good standing through their fleet delegates at the meeting.
5. In addition to the foregoing method of amendment, these By-Laws may be amended by the written consent of the majority of members. Fleets shall have such consent only upon vote of members at a meeting thereof or written consent of a majority of the fleet.
6. The Governing Board shall have the authority to simplify, clarify or correct the language of any article hereof or amendment hereto so long as the intent and purpose thereof remain unchanged.

~

APPROVED CHANGES

Approved Changes, listed below, reflect changes made for convenience and ease of operation that have been approved by the Governing Board. **Members shall not compete with modifications to the Lido 14 unless the change(s) in question are permitted by the By-Laws, the Official Certificate of Measurement and Registration, or this list of Approved Changes.**

Association members wishing to change their Lido 14 (solely for the purpose of convenience and/or ease of operation) in ways not fully covered by these documents are required to submit their proposed change(s) to the Association for approval prior to use of the change(s) in completion. Change requests shall be submitted in writing to the Chief Measurer. If the Chief Measurer rules in favor of the request, he/she will then seek the approval of the Governing Board. If the Governing Board ratifies the Chief Measurer's ruling, the change is noted as an "Approved Change" and will be, from that point, legal for use.

Competing with changes that are NOT approved by the Governing Board is a violation of Association By-Laws. Violators risk suspension from the Association.

1. **April 1997: The boom vang shall be rigged with maximum mechanical advantage i.e., Ratio: Force on boom/Applied by factor = any.**
2. **The main may be controlled by either a single or double purchase.**
3. **Aug. 2002: Pumping or bailing equipment is acceptable provided no hole is made in the hull to accommodate such equipment.**
4. **The mast may be filled with Styrofoam.**
5. **The mainsail outhaul may be extended forward to the boom vang fitting on the boom.**
6. **A shackle may be used on the end of the mainsail outhaul in lieu of the snap.**
7. **May 2001: Rescinded (concerning 2:1 purchase on mainsail outhaul).**

8. Hardware may be substituted for safety and convenience if the substituted hardware provides the same function as the original hardware and does not provide any additional function.
9. Any type of inflatable flotation is allowed under the foredeck.
10. A preventer in the mast slot track to stop the gooseneck fitting from sliding down is permitted.
11. It is permissible to run halyards to a jamb cleat affixed to the mast, in lieu of using cleats cast to the mast hinge.
12. Either a plain shackle or a swivel shackle may attach the jib sail to the deck fitting, but shall not exceed 1 1/2 inches in length for boats below #6000 or 3 1/4 inches for boats #6000 and above.
13. The mainsail downhaul may be secured to the mast by means of a jamb cleat.
14. To increase the operation of the jib halyard, the following procedure may be used: A single block, shackle, or loop of line may be attached to the jib halyard above the cleat on the mast-deck fitting. The halyard is continued around the lower end of the cleat, run up to the block, shackle, or loop, and then back to a cleat for securing.
15. A line may be run between the bow fitting and the mast to keep jib sheets from fouling on the mast fitting so long as this line is not adjusted while racing.
16. The use of a centerboard bumper strip applied to the underside of the centerboard cap to protect the trailing edge of the centerboard is permitted.
17. The use of a sleeve or strip for protection of outhaul on the end of the boom is permitted.
18. A roller-bearing traveler is permitted.
19. Extra holes drilled in the chain plate to achieve a better adjustment of the shrouds is allowed.
20. On Lido 14's with hull numbers below #6000, the forward ends of the hiking straps may be fastened to a rigid bar, which itself is fastened to the shroud chain plate area and the centerboard trunk. On Lido 14's with hull numbers #6000 and higher, hiking straps shall be attached to the points designed for this purpose by W.D. Schock Corporation.
21. Removal of the lip at the aft end of the centerboard slot, but not in excess or behind a line representing a continuation of the slope of the inside after edge of the center board trunk, is permitted.
22. Boom vang pad eye located in bilge forward of the centerboard trunk may be moved immediately forward to prevent interference of boom vang and centerboard arm.
23. A block of wood or other material may be molded in bilge forward of centerboard trunk for use of mounting boom vang fitting, centerboard tackle and hiking straps. Blocks of wood or other material may be molded or fastened to the centerboard trunk for mounting cam cleats or other items.
24. A jamb cleat is allowable on the boom for the purpose of securing the outhaul, in lieu of the toggle.
25. A jamb cleat (or jamming block) is allowable on the boom vang in place of the toggle.
26. Fittings may be placed on the cathedral cleats to prevent jib sheets from catching.
27. Spring loaded stops are allowable on the jib fairlead slides and the main traveler track.
28. Use of shock cord on the boom vang is allowable.
29. Drilling a hole in the bow for a bowline is permissible.
30. Installation of a watertight inspection port in the vertical surfaces of the bow tank is permissible.
31. A swivel jamb cleat may be placed on the top of the centerboard trunk for raising and lowering the centerboard. This swivel jamb cleat would replace the present jamb cleat currently used by most sailors.
32. The bottom 5 inches of the rudder and bottom 8 inches of the centerboard may be virtually

- any shape providing all other dimensional measurements have been complied with.
33. The mast position measurement is to be taken from the leading edge of the mast (stepped) to the center of the forestay pin 49 inches plus or minus 1/4 inch.
 34. Anchors are not required equipment.
 35. Modifications to the centerboard trunk and deck beam braces as provided by the manufacturer and without approval of the Governing Board are illegal.
 36. Aug. 1993: Rescinded (concerning restriction on tiller extension length).
 37. The tension of the mast diamond stays shall be such that the stays are a straight line with the mast supported horizontally from its ends and the spreaders vertically.
 38. The measurement length specified for jib fairlead and traveler track means length of track rather than the length from stop to stop.
 39. A centerboard will not be considered a jibbing board if the leading edge of the centerboard, that lies within the centerboard well or slot, does not move more than 1/4 inch more than the trailing edge of the board, when the board is pushed from side to side in the slot, as it would be when the boat is under sail and steered from one tack to the other tack while on a beat.
 40. Centerboard Measurement—The "leading edge" is interpreted as the predominant leading edge. It is measured by laying a straight edge along the predominant leading edge to a point on the hull. From this point, a measurement is made along the hull on the centerline to the transom/bottom intersection. The dimension is 95 1/2 inches plus or minus 1/2 inch.
 41. The sides of the centerboard slot at the bottom of the boat may be altered to create a minimum opening width of 1 1/8th inches. (This does not allow filling of the corrugations in the centerboard trunk.)
 42. Depth of the centerboard fully down from the bottom of the hull to the centerboard end is 48 inches plus or minus 1/2 inch.
 43. A 4 x 4" area may be built up at the point where the top of the fully extended centerboard comes into contact with the sides of the centerboard trunk in order to correctly align the centerboard, except as provided in Rules 41.
 44. A mast preventer may be rigged between mast and shroud.
 45. Snap connectors on the ends of the whisker pole.
 46. Aug. 2002: Rescinded: (concerning optional self bailing equipment). [Ed. See Article XIII.9].
 47. Seat cushions and/or padding may be used as boat ballast if securely attached while racing. These items are not to be considered nor used as personal flotation devices.
 48. Due to the danger and cost of broken booms the internal reinforcement of the boom shall be allowed. The reinforcing material can be metal or wood not to exceed 30 inches in length. It is recommended that the reinforcement be placed so as to span an equal distance on either side of the boom vang bail, or attachment.
 49. Jan. 1993: Repair or prevention of persistent cracks in gunwale is allowed.
 50. Installation of fabric or plastic bail on booms for main sheet support.
 51. A guard strip may be installed on the bow to protect the gel coat.
 52. A patch or strip of stainless steel, aluminum or other material may be placed on the front of the mast behind the thrompkin to protect the mast from wear caused by the whisker pole.
 53. A hook or similar device may be used to hold the whisker pole when not in use.
 54. The centerboard thickness may be increased up to 1 1/8 inches in the area up to 2 inches forward of the trailing edge of the board, and up to 3 inches below the intersection of the arm and the top of the board.
 55. The JSI-B Johnson Spar mast is a legal substitute for the W.D. Schock Lido 14 mast.
 56. All Lido 14 parts may be of any color finish or anodization.
 57. Sails with polyester (Mylar) thread and film may be used in non-championship regattas at

the discretion of the host fleet.

- 58. Nov. 1995: Revised May 2001: Any fitting or approved change for Lido 14's with hull number #6000 and higher may be used on Lido 14's with hull numbers below #6000 provided that there is no change in basic measurements, under water configurations, sail plan, or other features which affect boat speed. [Ed. See Article XIII.10].
- 59. Feb. 1996 & May 1998: Electronic compasses are OK use if that is their only function
- 60. Feb. 1997: It is permissible to store the whisker pole on the boom when not in use.
- 61. Feb. 1997: For Lido 14's with hull numbers #6000 and higher, a view port is allowed in the

Lido 14 Mast Preventer

Approved Change # 44

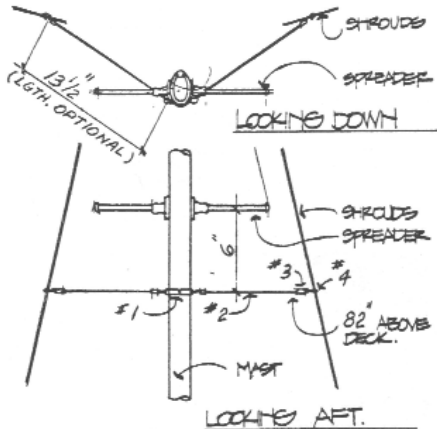

- Parts Inventory
- 1. S/S strap (e.g. RF27) attached to mast with pop rivet or sheet metal screw
 - 2. 1/16" covered 7x7 wire. 2 pieces
 - 3. 1/16" nico press. 4 pieces.
 - 4. 3/32" S/S thimble. 4 pieces

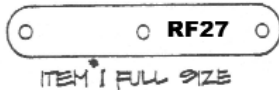

centerboard cap.

- 62. Feb. 1997: 6000 series boats may use a bulls eye fairlead for the bow line
- 63. Feb. 1997: 6000 series boats may use plastic halyard cleats
- 64. Feb. 1997: 6000 Series boats may use 2:1 purchase on centerboard retraction line
- 65. Feb. 1997: 6000 Series boats may reconfigure the centerboard shock cord
- 66. Feb. 1997: 6000 Series boats install a positive stop for centerboard down position
- 67. July 1998. Rescinded May 2002: (concerning cutting down of transom)
- 68. Aug. 1998: Telescoping tiller extensions are permitted
- 69. Aug. 1998: An insert (e.g. wood) may be placed between the inner and outer centerboard trunks on the 6000 series boats at the point where the seats meet the trunk in order to restrict side to side movement of the inner trunk.
- 70. Aug. 1998: The minimum width of the centerboard slot shall be 1 1/8"
- 71. May 2001: It is acceptable to remove material from the post 6000 Series mast butt [ed. the bottom end of the mast extrusion] as long as the height of the mast above the deck is not

altered

- 72. May 2001: The "Classic Lido" mast butt fitting is allowed for use on all Lido 14s
- 73. July 2001: A roller fitting (Ronstan RF 453 or equivalent) may replace the stock cast boom end fitting, and be attached to the end of the boom to guide a single outhaul line from the clew of the mainsail either around or to the inside of the boom. Blocks and line may be attached to the outhaul in any combination to gain mechanical advantage. The angle of the line from the clew to the end of the boom must be essentially the same as with the stock factory fitting, and all rigging must be within or attached to the boom. Refer to the sketch in the back of the Handbook.
- 74. July 2001: Shrouds shall have plastic covering along their entire length except that a reasonable amount may be removed from the ends of each shroud for the purpose of attaching end fittings. In addition, a maximum of 3/8 inches of plastic covering may be removed from the middle area of the shroud for the purpose of flying one set of tell-tails.



Andrew McDade & Will Gresham at the 2002 Junior Class Championships on Mission Bay

DISSALLOWED CHANGES

1. Rubber strips covering the centerboard well opening on the bottom of the hull.
2. Mast stay release mechanism allowing the boom to pivot farther forward going down wind.
3. Re-rigging the mainsheet with multiple blocks on the end of the boom and transom.
4. The use of shims, wedges and rollers to prevent centerboard side-play, except as provided in Approved Changes 41 & 43.
5. Double transoms to accommodate outboard motors.
6. Filling of the corrugations or any portion of the centerboard trunk.
7. Adjustable luff ropes in jib sails not sewn to luff rope at one or both ends.
8. Use of block or cord preventer on whisker pole.
9. Use of shock cord to hold tiller in center of boat while sailing.
10. Telescoping and/or adjustable whisker pole.
11. Running halyards through fairlead and then to a jam cleat.
12. Use of an outhaul winch.
13. Use of a snap shackle at the jib tack.
14. Attach any restraining device to clew grommet on main other than outhaul.
15. Changing of hull number.
16. The running of halyards through holes or fairleads in the deck.
17. The addition of additional hardware to the jib fairlead track.
18. Use of the whisker pole as a reaching outrigger, on the same side as the boom.
19. Use of a double block or two (2) single blocks on the centerboard arm.
20. Straight traveler track (track must conform to the curvature of the transom).
21. Removal of the cathedral cleats.
22. Jam cleats on each side of the boat to operate and adjust the traveler slide for mainsheet.
23. Use of Proctor tapered mast.
24. Small winch on top of centerboard cap to aid in controlling the jib sheets rather than use of jam cleats.
25. July 2001: Moved to Approved Change #75 (concerning plastic coating on shrouds).
26. Removal of wooden tray.
27. Installation of shock cord to hold boom forward while running.
28. Boom mounted mainsheet jam cleat.
29. Running the centerboard shock cord inside the centerboard trunk instead of outside the centerboard trunk on any Lido 14's with hull numbers below #6000.
30. Placement of two (2) windows on either the mainsail or the jib sail.
31. Paint on the bottom of the boat that may result in less friction than the clean smooth gel-coat that is on the boat when it arrives new from the factory.
32. Rescinded (concerning the use of "cam cleats").
33. The use of clear plastic centerboard caps.
34. Aug. 1995: Rescinded (concerning addition of a downhaul block at the mainsail tack).
35. A change in the jib sail design providing a continuous flap to attach the jib sail to the foresail and fastened by a series of snaps.
36. July 2001: Rescinded (concerning limited swinging spreader)
37. Alterations of the centerboard trunk to make it longer or higher.
38. Rescinded (concerning the use of a ratchet block for main sheet control).
39. Use of more than one (1) gudgeon on mast for whisker pole attachment.
40. Use of the thru-hull operated knot meter.
41. Moving the jib fairlead track and stops at the ends of the metal track controlling the jib fairlead, and re-bolting the stops to the gunwale to permit additional forward or aft movement of the fairlead along the 18 inch metal track is not allowed.
42. A split or double mainsheet.

Member Roster - By Boat Number

<u>Boat</u>	<u>Fleet</u>	<u>Member Name</u>			
3	6	Switzer, Robert	3210	78	Glade, Tom
273	Unattached	Caratan, Milan	3281	6	Smith, Dave
481	62	St, Chuck	3391	81	Ispas, David
773	7	Davies, Roy	3446	9	Schaffel, Gary
989	6	Thompson, Jim	3515	1	Bartell, Renee
999	62	Nugent, John	3542	7	Carroll, Dave
1007	1	Rossen, Dan	3547	25	Runyan, Ron
1072	7	Hochart, Charlie	3572	7	Weinberger, Mark
1414	6	Tripp, Charles	3618	59	Rothenbuecher, Peter
1542	6	Bell, Sam	3622	78	Abelman, Fred
1582	6	Sheppard, Daniel	3622	78	Morrow, Kent
1686	Unattached	Hansen, Anne	3650	1	Boudreaux, Greg
1815	40	Harding, Mike	3660	77	Harris, Fred
1952	81	Stults, Allan	3668	1	Crisfield, Rick
1963	77	Lincoln, Kenneth	3673	78	Miller, Mark
2132	Unattached	Brew, Greg	3696	6	Storms, Jim
2146	1	Welch, Randy	3720	25	Brown, Duncan
2166	6	Bateman, Jim	3731	25	Heisel, Carl
2181	77	Richard, Dennis	3737	80	Frangooles, Bob
2223	81	Heald, Chris	3804	6	Porter, Dave
2223	81	Romanini, Michael	3822	7	Ericksen, Dick
2309	7	Good, Christopher	3857	57	McDonald, Bill
2317	62	Lee, Sidney	3901	59	Duthie, John
2445	40	Allen, Charles	3906	7	Hinton, Roger
2501	7	Callender, Dave	3909	7	Machado, Ed
2505	81	Krokus, Don	3910	40	Howlett, Don
2540	6	Clanton, Ron	3945	40	Compton, Sam
2577	6	Phillips, William	3997	25	Moentenich, Lorin
2614	6	Stevens, Fred	4013	40	Nolan, Sean
2665	62	Michel, Butch	4030	6	Siemer, Bob
2707	9	Spero, Bob	4048	7	Davis, Peter
2761	59	Gamill, Roy	4061	77	Vizzini, Lisa
2800	25	McGeevy, Thomas	4078	59	Jenkins, Thomas
2831	57	Ostler, Mark	4110	1	Woolsey, Roy
2843	7	Kunsmann, Kerry	4111	9	Rand, Marvin
2853	6	Gonzales, Dianne	4114	1	Hinshaw, Ted
2854	Unattached	Sinclair, Jerry	4141	9	Miller, Al
2859	1	Leisure, Marr	4151	78	Barrett, Patrick
2862	40	Bovaird, Leslie	4174	40	Hoover, Richard
3000	59	Rygh, Pat	4179	7	Martin, Bob
3072	6	Svilicich, Mike	4205	57	Albright, Bob
3101	7	Land, Anne	4238	59	Bagby, Lynne
3107	81	Joyce, Richard	4279	78	Schoenrock, Gary
3111	59	Orth, Jim	4283	80	Garlock, Tim
3113	7	Robertson, Stu	4285	62	Navarra, Jack
3139	57	Polites, Pete	4300	7	Williams, Grant
3141	57	Rosen, Mike	4354	59	Hensley, Terence

4374	81	Leech, Bruce	5121	62	Davis, Joe H.
4390	62	Gordon, Gary	5127	1	Davidson, Nancy
4391	1	Williams, Paul	5127	1	York, T.L. Missy
4399	Unattached	Livers, Pete	6004	59	Benson, John
4407	1	Potts, Dennis	6006	6	Brown, Margie
4469	1	Johnson, TJ	6009	78	Johns, Garrett
4480	7	Foster, Kent	6010	25	Davidson, Clay
4483	1	Doyle, Brian	6015	7	Tilton, Roger
4508	40	Clark, Brian	6025	77	D'Amico, Joe
4509	7	Campbell, Ken	6026	1	Simenz, Rod
4524	77	Butler, Don	6037	77	Duoos, Dick
4532	6	Brown, Kevin	6041	7	Betts, Stan
4550	6	Gresham, John	6048	1	Forquer, Jim
4554	6	Brannin, Wayne	6051	59	Salas, Larry
4568	80	Canty, Dennis	6053	25	Salas, Steve
4578	40	De La Garza, Teyo	6055	79	Temple, Bud
4585	59	Hendricks, Kenton	6087	7	Canon, Terrie
4602	Unattached	Collins, Chris	6088	6	Dooros, Dan
4613	79	Osborne, Richard	6100	7	Janney, Brian
4631	59	Hendricks, Steve	6104	1	Derosa, John
4787	77	Peters, Thomas	6127	7	Patterson, Roger
4794	6	Rodgers, Gregory	6128	6	Canny, Rick
4819	7	Sturm, Aaron	6131	78	Orsini, Steve
4821	7	Marks, Frederick	6132	78	Hawken, Grey
4827	6	Ferramola, Gabriel	6136	6	Shlens, Debbie
4834	6	Turigliatto, Jon	6138	78	Skubi, Byron
4846	25	Hantke, Paul	6140	6	Serina, Don
4847	57	Bailey, Ted	6163	1	Bretschger, Peter
4865	1	Thorne, Gary	6165	6	McDermaid, Jeff
4875	62	Doering, Joseph	6166	59	Boertje, Dennis
4932	25	Bowen, Marc	6166	7	Kownacki, Eric
4955	59	Vowell, Jack	6187	80	Carson, Jeff
5000	6	Waterman, Maggie	6188	1	Papadopoulos, John
5024	6	Taughner, Donald	6188	1	Sih, Brady
5026	57	Bankiewicz, Mike	6197	1	Kaltenbach, Eric
5030	6	Church, Stan	6201	59	Horswill, Joe
5031	1	Papadopoulos, John	6203	81	Kontra, Robert
5033	62	Crozier, Kevin			
5036	7	Henke, John			
5040	Unattached	Kip, Christopher			
5040	Unattached	Kip, Grant			
5050	59	Lockwood, Don			
5051	1	Yates, Bob			
5058	6	Baumann, Mike			
5060	59	Giddings, Ron			
5088	6	Burdge, Don			
5100	1	Faillers, Stephanie			
5110	77	Daubenberger, Joe			
5115	1	Perez, Al			
5116	1	Mendoza, Jay			

**Lido 14 Class Association
P.O. Box 1252
Newport Beach, CA 92663**

www.lido14.org

Front Cover: Ryan Karnes and Stephanie Carroll at the 2002 Junior Class
Championships on Mission Bay (San Diego, CA)

Photos by Jonathan Carroll & Grant Williams